

UPLIFT DESK® Large Keyboard Tray

UPL127

Package Contents:

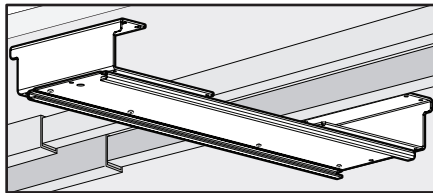
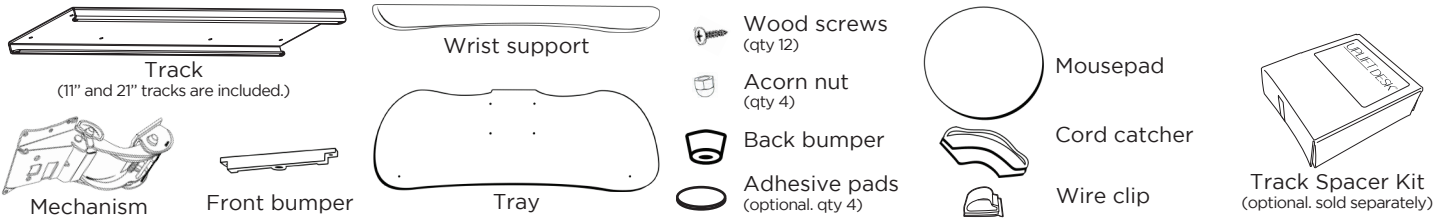

***A note before you begin:**

Determine where to mount the Keyboard tray. If you need to mount it over the Crossbars of your desk AND you ordered the optional Track Spacer Kit, open the box containing the Track Spacer Kit and follow those instructions inside.

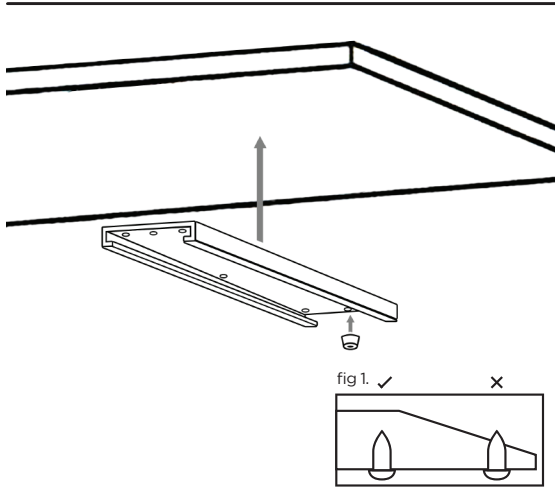

Step 1

Take the Track and place underneath your desktop, in order to figure out which size to use (11" or 21" Track) and where to place it. If there are pre-drilled holes in your desktop, line the track up with the holes. If there are not pre-drilled holes, drill your own pilot holes using 1/8" diameter drill bit and drill 1/2" deep. Be sure to leave about 1/2" from the front of the desk. Use eight (8) Wood screws to attach the 21" track, and six (6) Wood screws to attach the 11" track to the desktop. Use one (1) more screw to attach the Rear bumper as shown.

Caution:

When using screws on a desktop with a center-cut ergo edge, take care to ensure that the screw is not close to the ergo edge to avoid piercing the desktop with the screw. (see fig. 1)

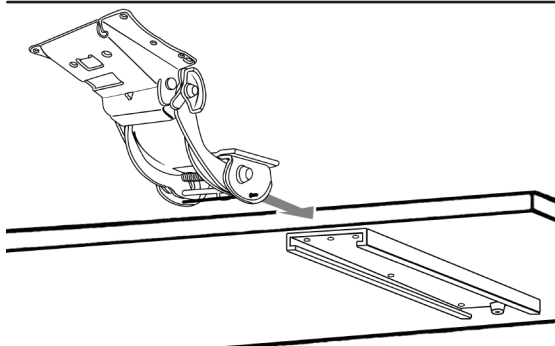

Step 2

With the desk right side up, line up the mechanism with the grooves on the track and slide it in. Please note: the mechanism will not adjust up or down until the tray has been attached and the shipping pin is removed (see steps 3 and 4).

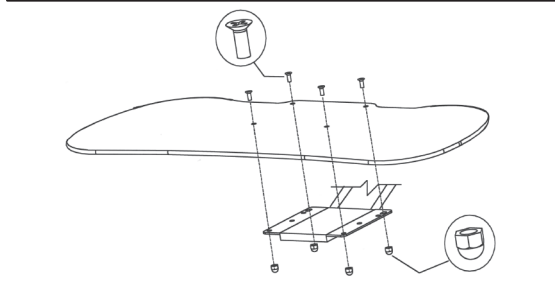

Step 3

Attach the tray to the mechanism by lining up the holes in the tray with the holes on the mechanism, and secure by inserting the four (4) Machine screws through the holes, and screwing the four (4) Acorn nuts onto them from below.

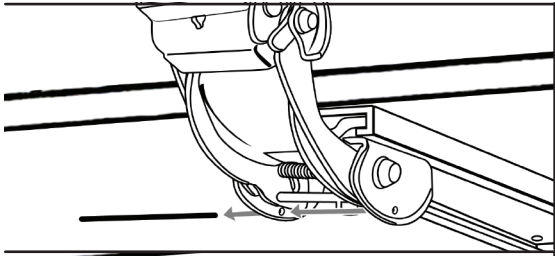

Step 4

Lift up on the front of the tray and lower the back to relieve pressure on the shipping pin and remove it.

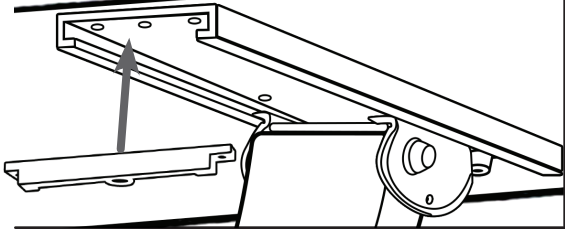

Step 5

Finally, lower the tray, slide it back on the track and install the front bumper using three (3) Wood screws.

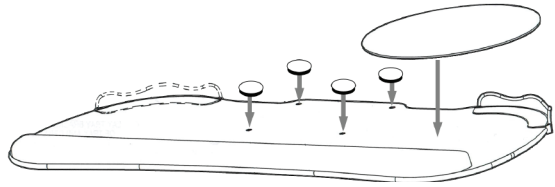

Step 6

Attach the foam palm support onto the front of the tray. Place the mousepad and cord catcher to the desired side.

The non-slip Adhesive pads can be placed over the heads of the machine screws, or in any other position on the board.

Use the Wire clip anywhere to secure loose wires to prevent snags.

Adjustment Guide

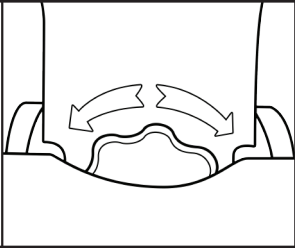

Tilt

To adjust the tilt of the tray, turn the knob at the center of the tray.

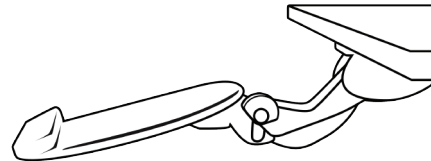
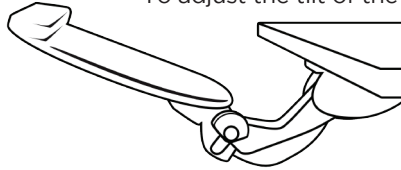

Height

To adjust the height of the tray up and down, push down on the back of the tray while lifting the front.

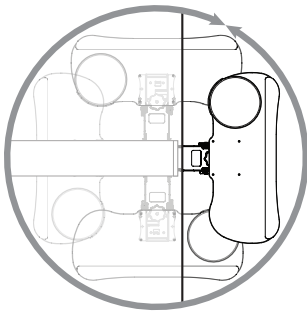
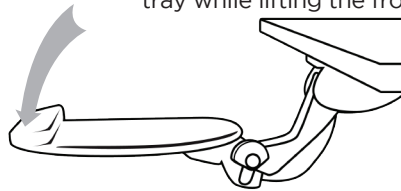
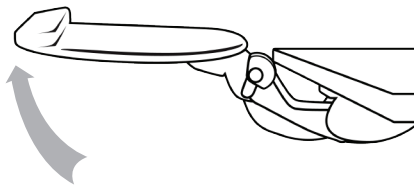

Rotate

The Keyboard Tray rotates at the point where the mechanism attaches to the Track. It can rotate 360 degrees.



CAUTION: Read all instructions before assembly. Failure to assemble properly may result in product damage or injury.