

UPLIFT DESK®

UPLIFT Adapt Freestand™ Instructions UDA100~freestand

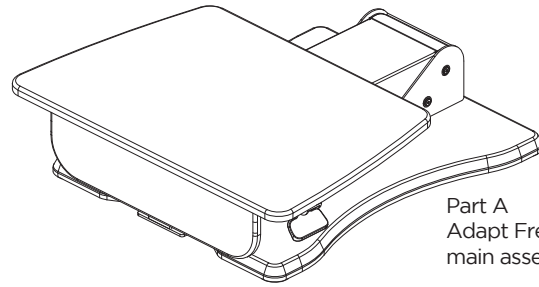
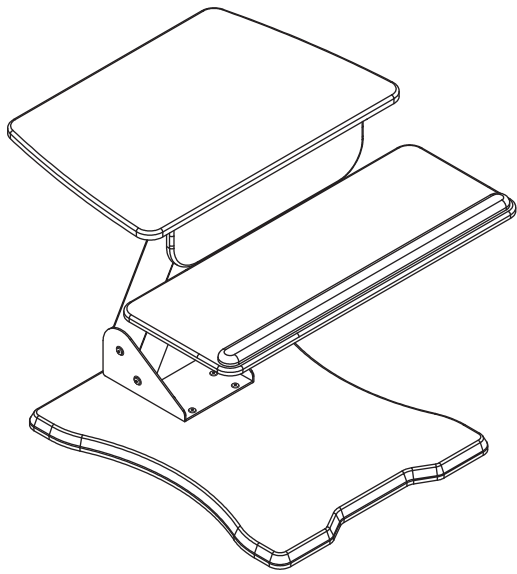

Part B
keyboard tray

Part A
Adapt Freestand
main assembly



Part C
Allen wrench (large)



Part D
Allen wrench (small)



Part E
M6*10 bolts Qty. 2



Part F
bolt covers Qty. 2

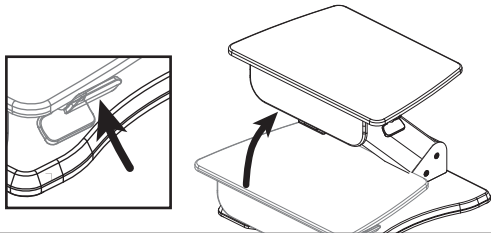

Step 1

Press and hold the release paddle in the up position on the UPLIFT Adapt main assembly (Part A) to raise the worksurface to the highest position. Release the paddle to lock in place.

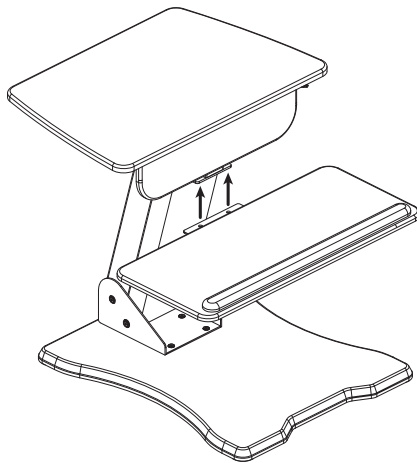

Step 2

Line up the holes on the plate of the keyboard tray (Part B) with the holes on the vertical connector under the main assembly's work surface.

Attach keyboard tray to the main assembly using two M6*10 bolts (Part E) and tighten using the small Allen wrench (Part D).

Cover the bolts with the adhesive bolt covers (Part F) by placing them, sticky side down, on the heads of the exposed bolts.

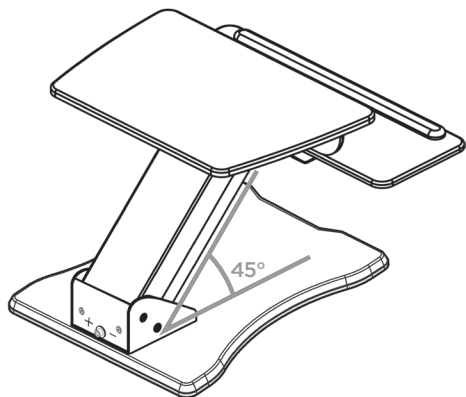
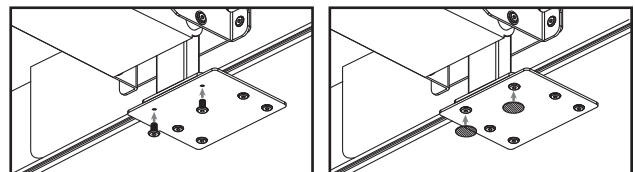

Step 3

Lower the unit until the main support column is at a 45° angle. Using the larger Allen wrench (Part C) and the tension adjustment bolt on the rear of the unit, adjust the tension for smooth operation. Turn clockwise to lessen the tension or counterclockwise to increase it. You may need to make further adjustments once equipment, such as monitors and keyboards, are placed on the unit.

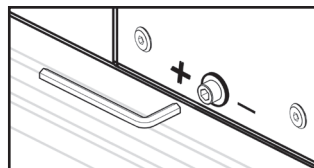

Step 4

Adjust the height of the unit by squeezing the release paddle and moving to desired position.

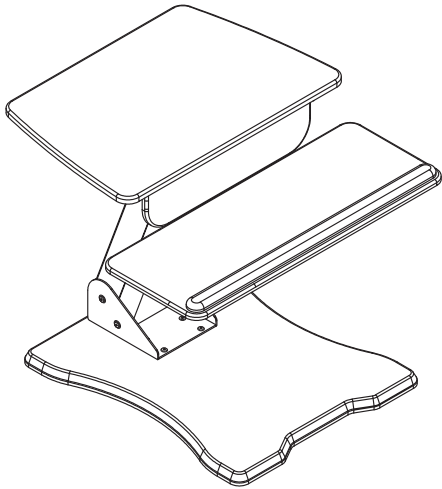
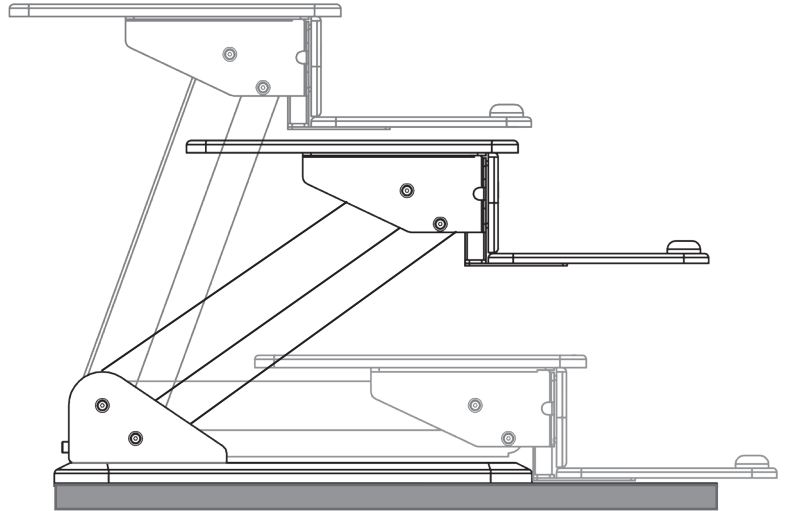
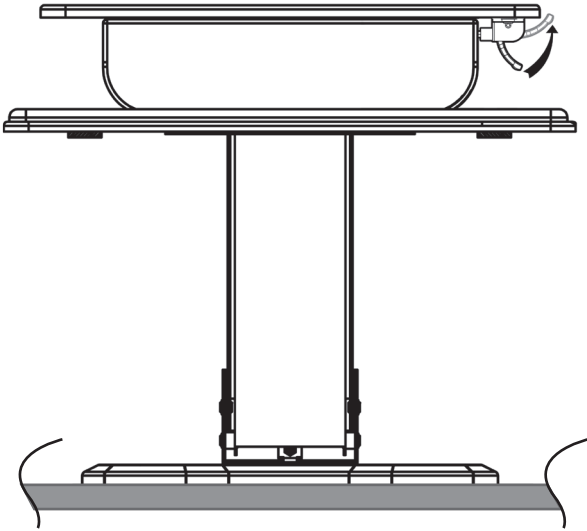

Please note

- The maximum load capacity of the UPLIFT Adapt Freestand is 28.6 lbs. Do not overload.
- Do not lean on or apply excessive pressure to the keyboard tray, unit may tip over.
- Do not position the keyboard tray to hang over the edge of your desktop when in the lowest position. The keyboard tray is designed to rest ON the desktop to prevent tipping.
- Failing to follow these safety precautions voids your warranty and may result in property damage or personal injury.

© Copyright Notice

These instructions are a component of the UPLIFT Adapt Freestand™. These instructions are part of the scope of delivery, even if the item is resold.

These instructions are also available on the UPLIFT Desk website: upliftdesk.com

Excerpts or copies may not be forwarded to third parties or used in any other published form without the prior written consent of UPLIFT Desk.

These instructions are subject to United States copyright law.