

Remove all items from the carton . Verify all pieces before assembly.

PART LIST

KEY QTY	DESCRIPTION	KEY QTY	DESCRIPTION	KEY QTY	DESCRIPTION	
1	5	Caster	7	1	Backrest	
2	1	Base	8	1	Backrest Post	
3	1	Seat Post	9	2	Backrest Screw	
4	1	Seat Post Cover	10	1	M5 Size Allen Wrench	
5	1	Mechanism	11	1	Backrest Bolt + Washers	
6	1	Seat	12	1	M6 Size Allen Wrench	
				13	1	Backrest Post Bellow
				14	2	Arm Bracket
				15	2	Armrest
				16	2	Arm Width Adjustment Knob + Washers

STEP 1.

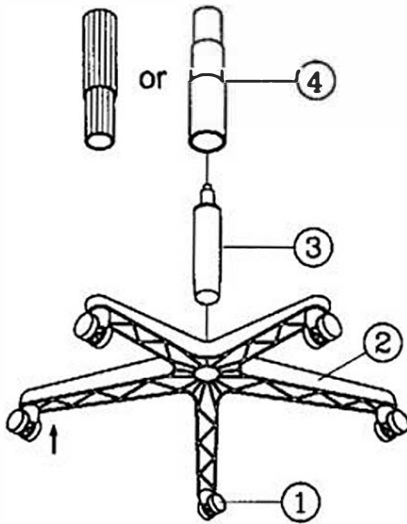

STEP 2.

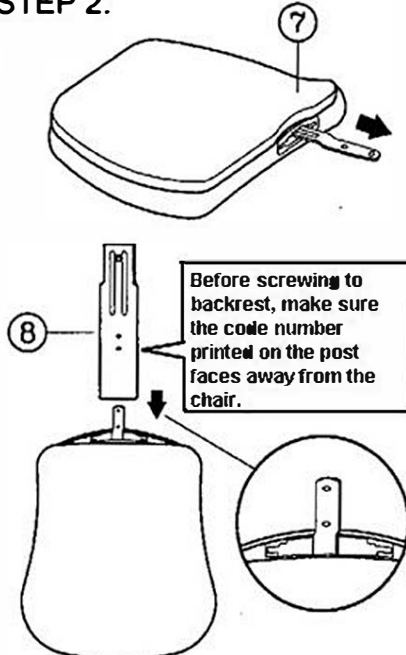

STEP 3.

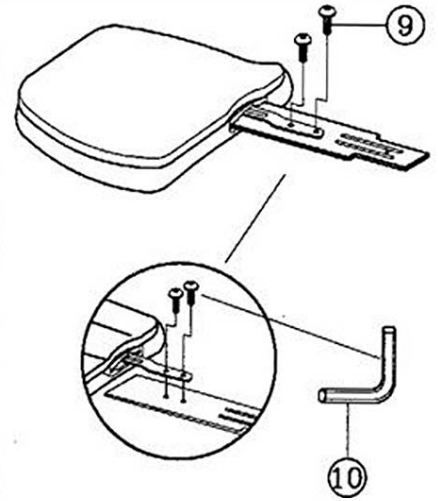

STEP 4.

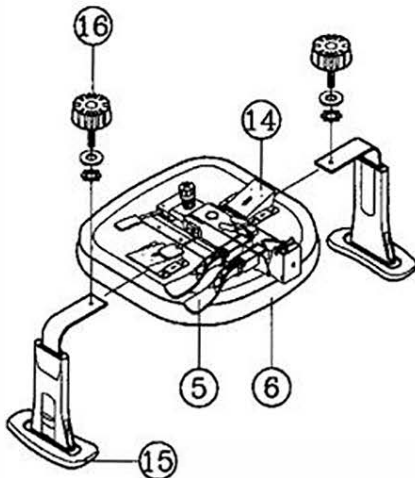

STEP 5.

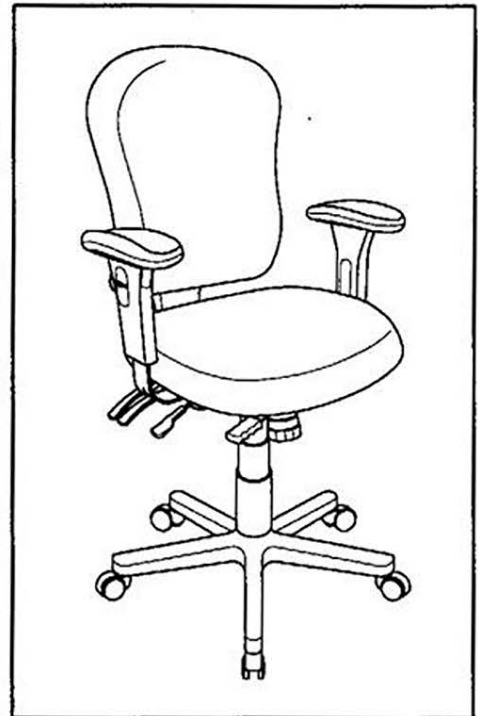
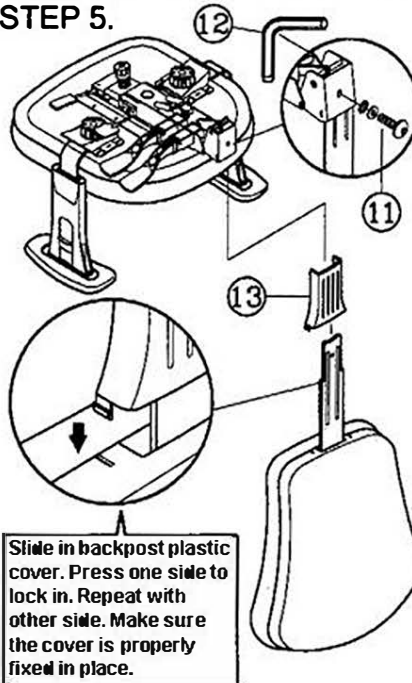

PREVENTIVE MAINTENANCE AND WARNING!

- USE THIS PRODUCT ONLY FOR SEATING ONE PERSON AT A TIME.
- DO NOT USE THIS CHAIR AS A STEP LADDER.
- DO NOT USE CHAIR UNLESS ALL BOLTS , SCREWS AND KNOBS ARE TIGHTENED . AT LEAST EVERY SIX MONTHS . CHECK ALL BOLTS , SCREWS AND KNOBS TO BE SURE THEY ARE TIGHT.
- IF ANY PARTS ARE MISSING , DAMAGED OR WORN , STOP USE OF THE PRODUCT UNTIL REPAIRS ARE MADE USING FACTORY AUTHORIZED PARTS.
- FAILURE TO FOLLOW THESE WARNINGS COULD RESULT IN SERIOUS INJURY.

available at:

 **humansolution**

800.531.3746

info@thehumansolution.com
thehumansolution.com