

CPU555, CPU555SEC Installation Instructions

CPU555

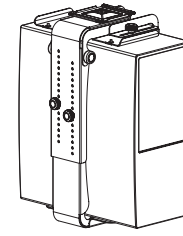

CPU555SEC

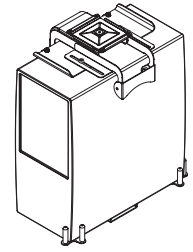

1a. Assemble CPU555

For CPUs Wider than 6"

Adjust width of Bottom Support by loosening Knob under Bottom Support and sliding Outer Bracket to width of CPU or to fully extended position as desired. Retighten Knob.

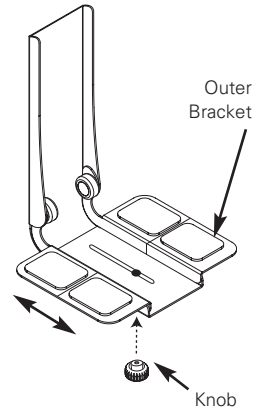

For CPUs 3" to 5" Wide

Install extension bracket.

- a. Remove nuts from extension bracket. Leave washers on posts. (a)

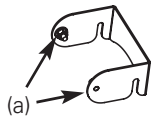

- b. Unscrew rubber bumpers from CPU555. (b)

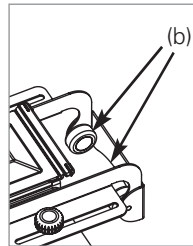

- c. Screw rubber bumpers onto extension bracket. (c)

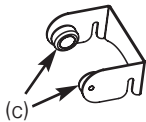

- d. Slide extension bracket over threaded posts. Tighten down with nuts. (d)

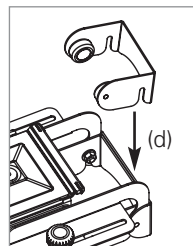

1b. For CPU555SEC Installations, Attach Security Brackets to Holder

Place Security Brackets on top of Bottom Support as shown. Insert Spacer between Security Brackets and Bottom Support and position over center hole for CPUs 5"-7" wide (for narrower CPUs, use one of the inner holes, for wider CPUs, use one of the outer holes.) Insert Screws into top of Security Bracket as shown and fasten loosely with Security Nuts.

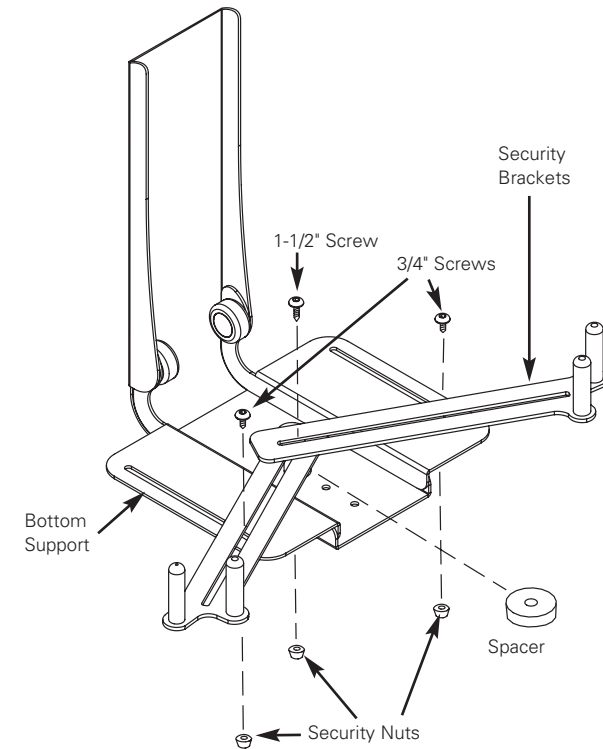

CPU555, CPU555SEC

Installation Instructions

CPU555

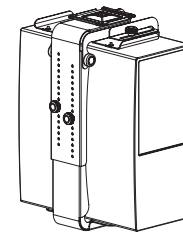

CPU555SEC

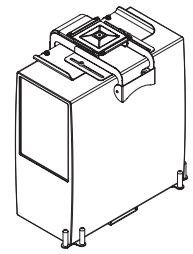

2. Install CPU into Holder

Place CPU on Bottom Support. Loosen Side Support and fit Top Support tightly over CPU. Fasten with Knobs or Security Nuts as necessary. Adjust Side Support so that it fits securely against CPU and tighten Knobs or Security Nuts. For CPU Security installations, position Security Brackets tightly against corners of CPU (as shown) and tighten Security Nuts underneath Bottom Support.

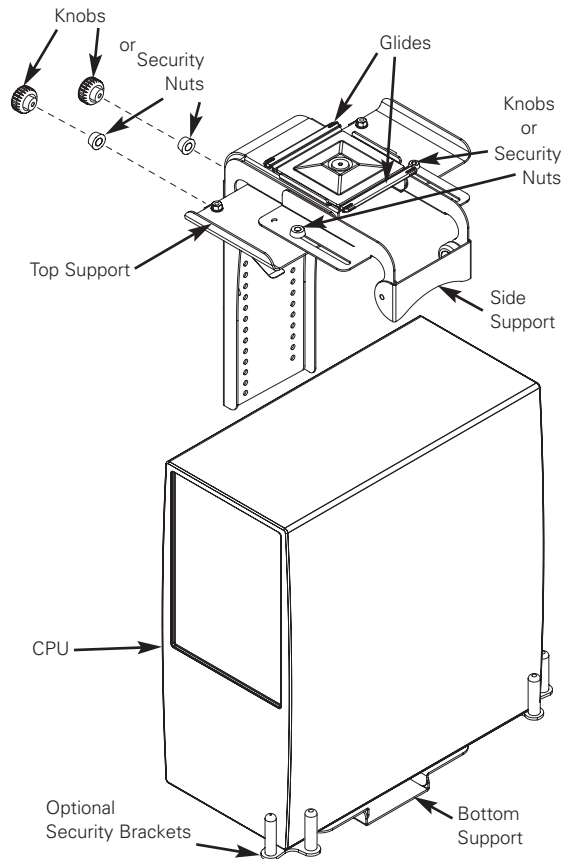

3. Install the Track

Using tape, affix Track to underside of desk. Drill holes. Using screws provided, attach Track and Rear Rubber Stopper. Making sure plastic glides are in place, slide CPU Holder onto Track. Attach Front Bumper to Track.

