

## WARNING



WARNING: FAILURE TO CAREFULLY FOLLOW ASSEMBLY, SAFETY, AND OPERATION INSTRUCTIONS AND WARNINGS REGARDING THIS PRODUCT MAY RESULT IN BODILY INJURY AND/OR PROPERTY DAMAGE.

**Liability:** The manufacturer does not accept warranty claims or liability claims for damages arising from improper use of Winston-E. For safe use, do not place any objects or body parts underneath the work surface. Make sure no body parts, objects or furnishings are located above the Winston-E. When using Winston-E, make sure no hands, fingers or other body parts are near the lifting column or between the cross beam and work surface. Winston-E must be set on a level, stable surface for safe use.

**Additional Warning:** Do not use Winston-E if it has a damaged cord or plug. Winston-E should not be carried by the cord. Pull on the plug, not the cord, to unplug Winston-E. Keep liquids away from Winston-E. Keep hair, loose clothing, fingers, and body parts away from openings and moving parts.

Switch off power supply and remove main power supply plug before installation or troubleshooting. Ensure no cables or cords can get jammed or stripped when raising or lowering Winston-E. Ensure all wires are not entangled in the Winston-E and have enough length when the unit is raised to the desired height.

**WINSTON-E IS NOT A TOY.** Children should not use Winston-E. Do not crawl, lie, or move around the unit. Do not sit, kneel, or stand on the work surface. Do not use Winston-E if you are distracted or are under the influence of medications that can cause diminished control. Winston-E is not a toy and should only be installed and used by someone familiar with and capable of adhering to the warnings and instructions.

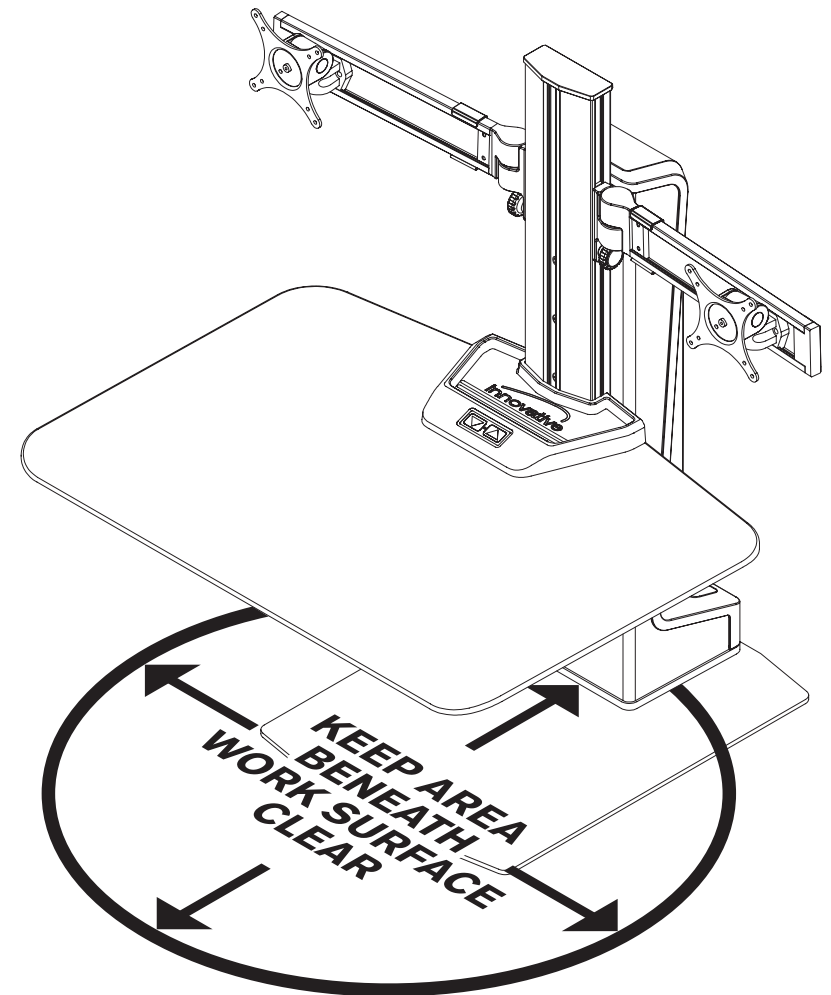

## WARRANTY

Winston-E includes a 5 year limited warranty. This limited warranty covers any defects in materials and workmanship of the product. This limited warranty may not cover problems, damage or injuries caused by misuse, accidents or abuse. The manufacturer may require proof of purchase before performing any repairs or replacing products during the warranty period. This warranty is non-transferable and applies only to the original purchaser.

**STEP 1** | FREESTANDING BASE..... Page 4

**STEP 2** | WORK SURFACE..... Page 5

**STEP 3** | WINGS..... Page 7

**STEP 4** | MONITOR TILTER..... Page 8

**STEP 5** | CABLE MANAGEMENT..... Page 9

**STEP 6** | BUTTON PROGRAMMING..... Page 10

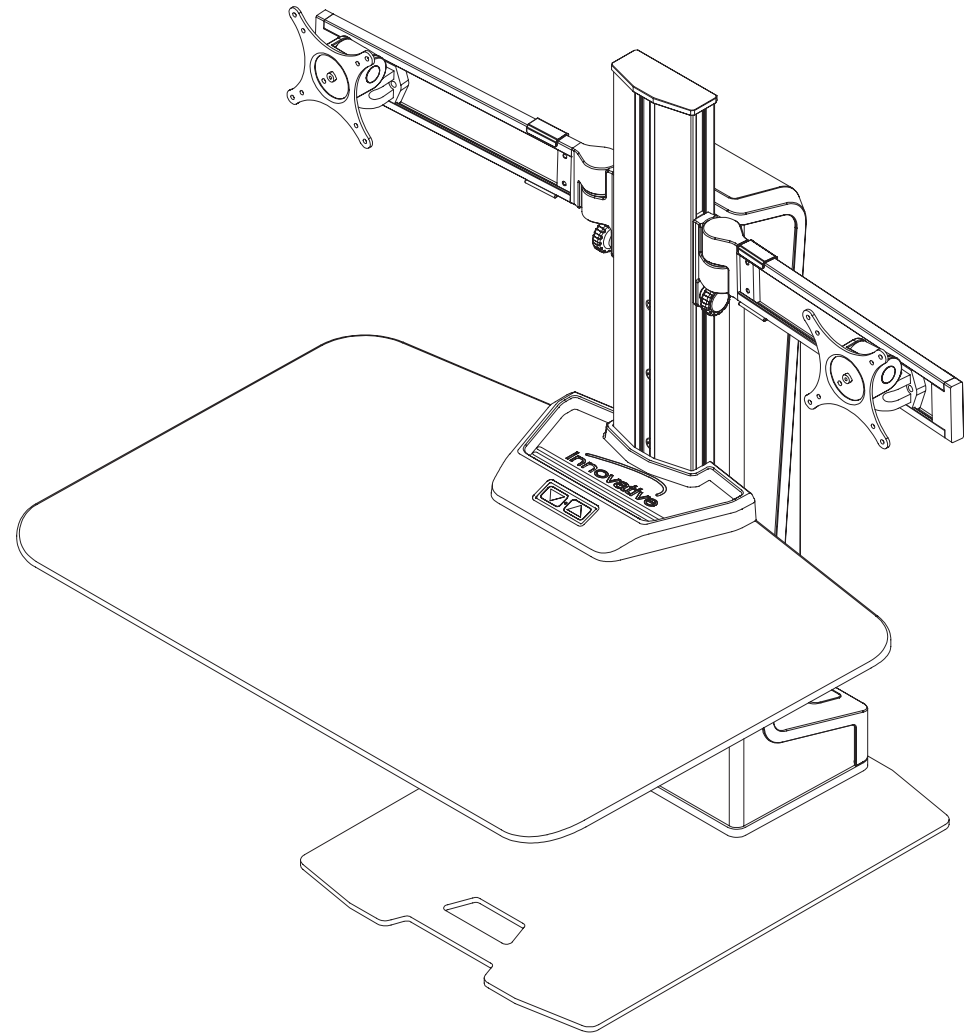

# WNSTE-2

## Winston-E™ Workstation Dual | Parts List

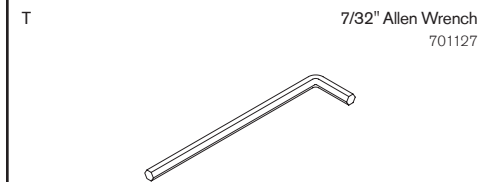
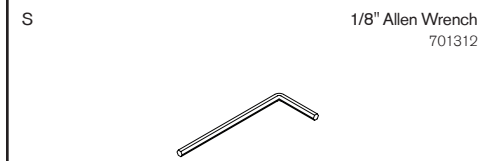
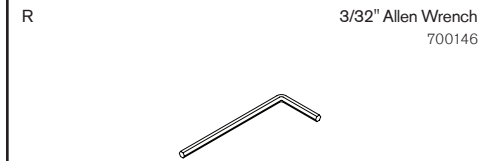
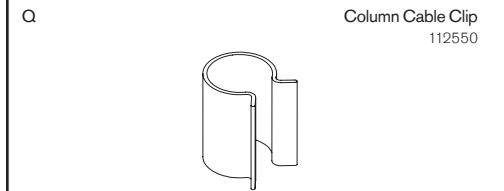
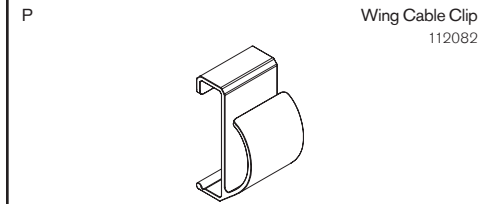
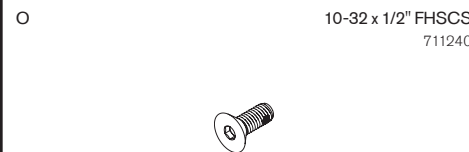
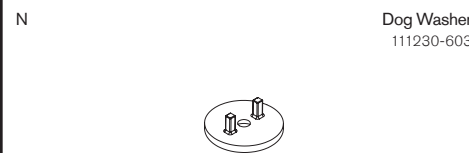
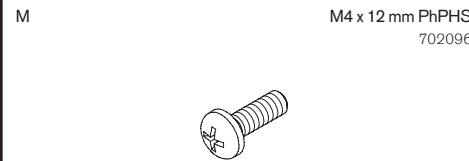
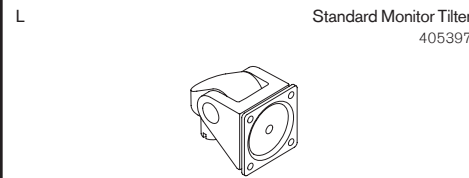
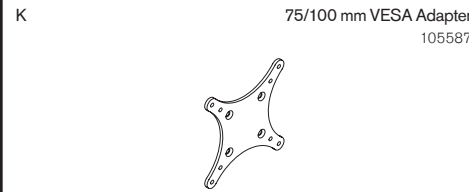
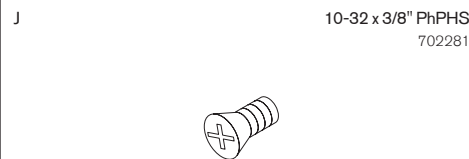
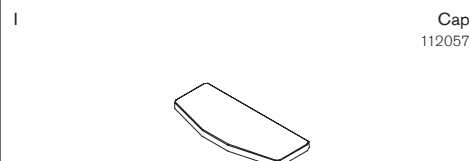
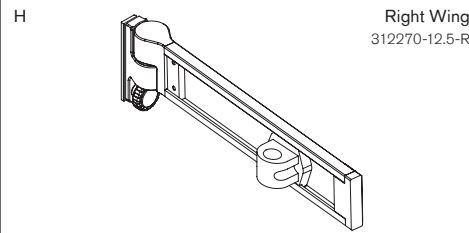
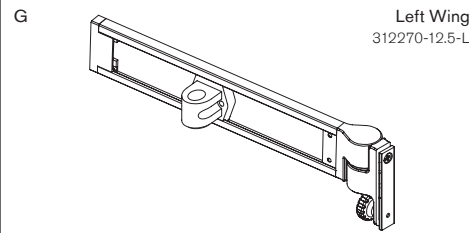
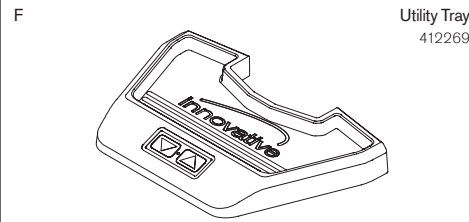
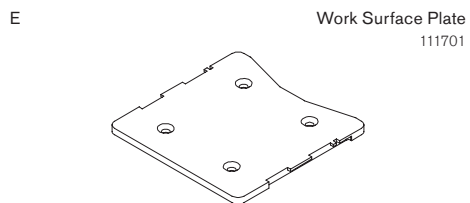
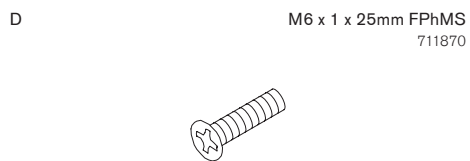
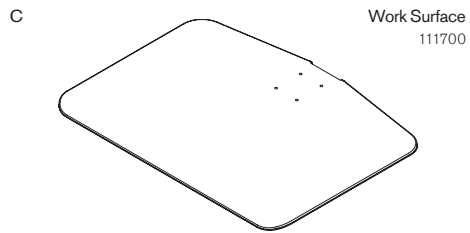
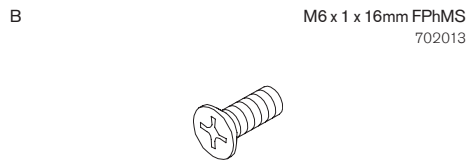
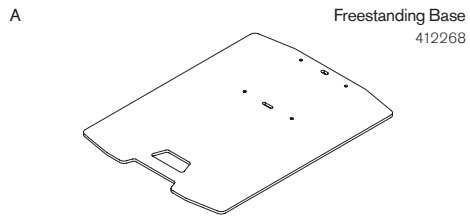

# STEP 1

# FREESTANDING BASE

1

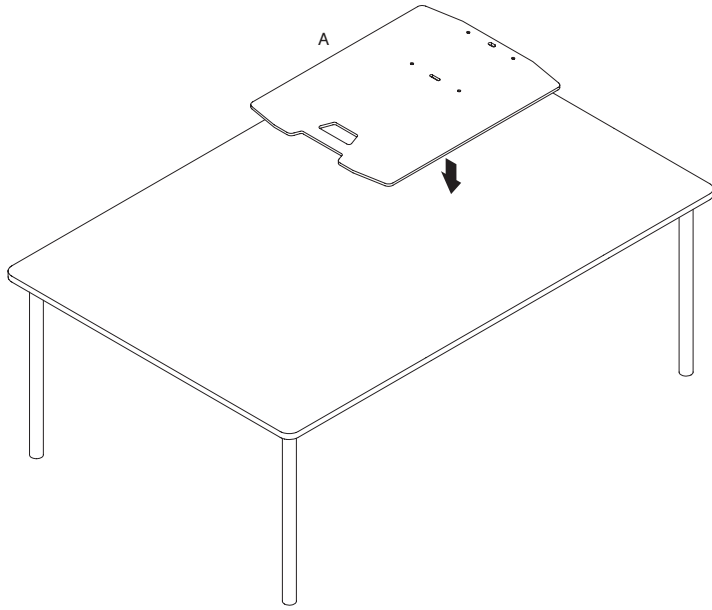

2

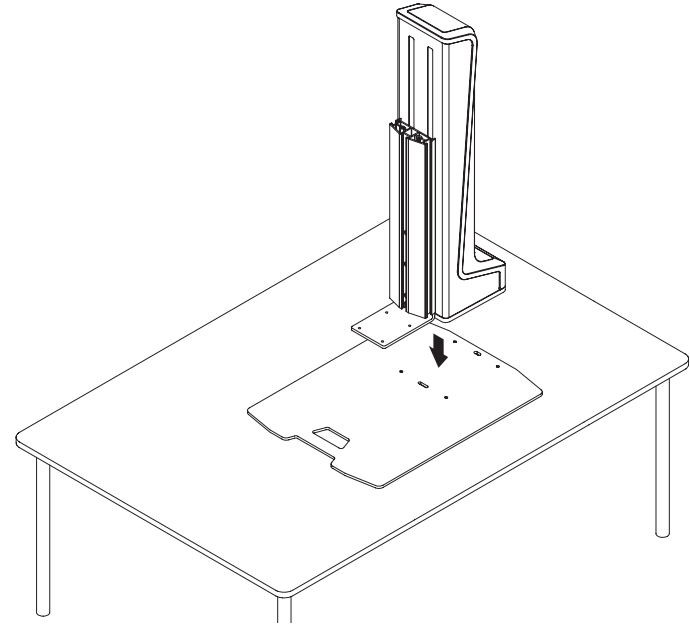

3

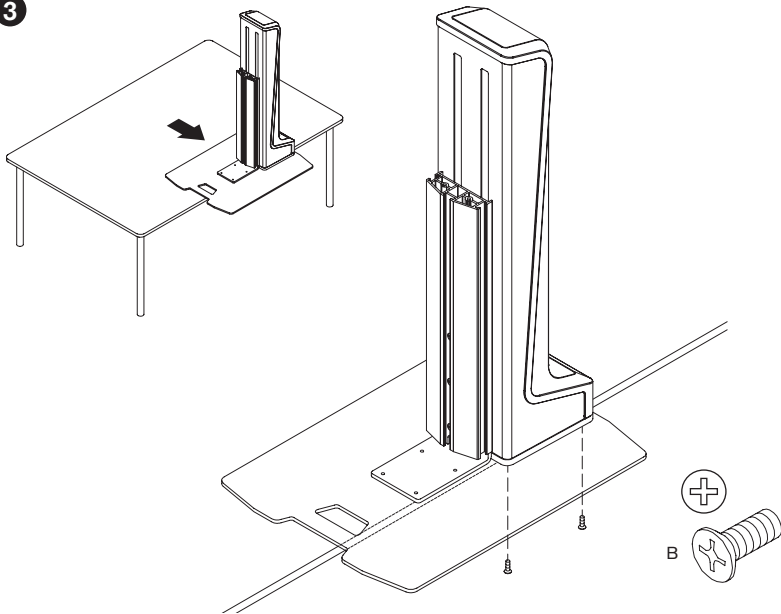

4

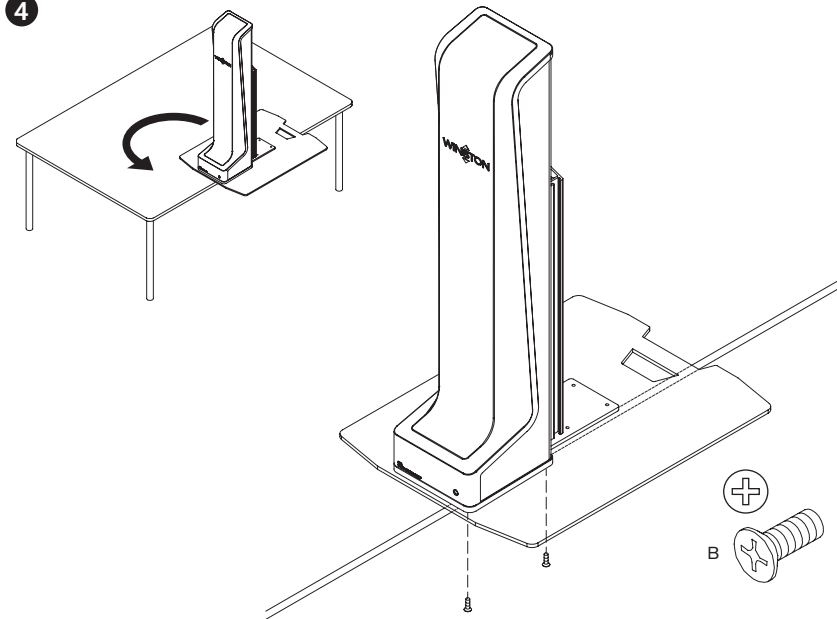

# STEP 2

# WORK SURFACE

1

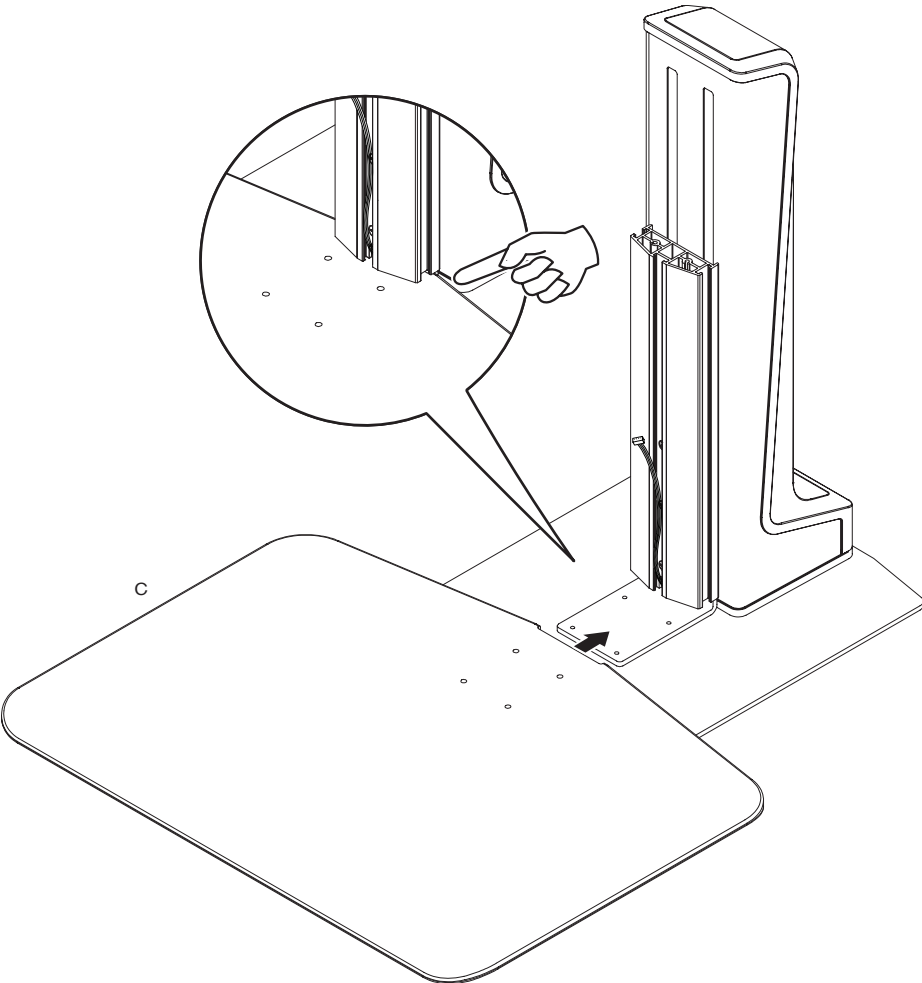

2

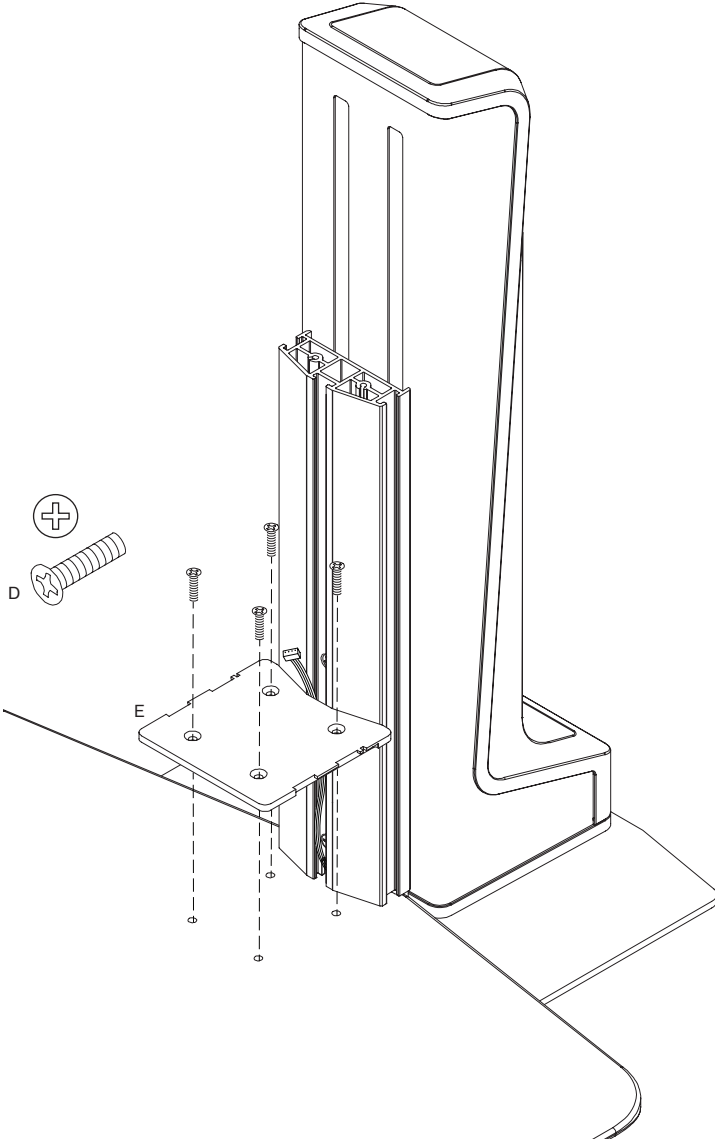

# STEP 2

# WORK SURFACE

3

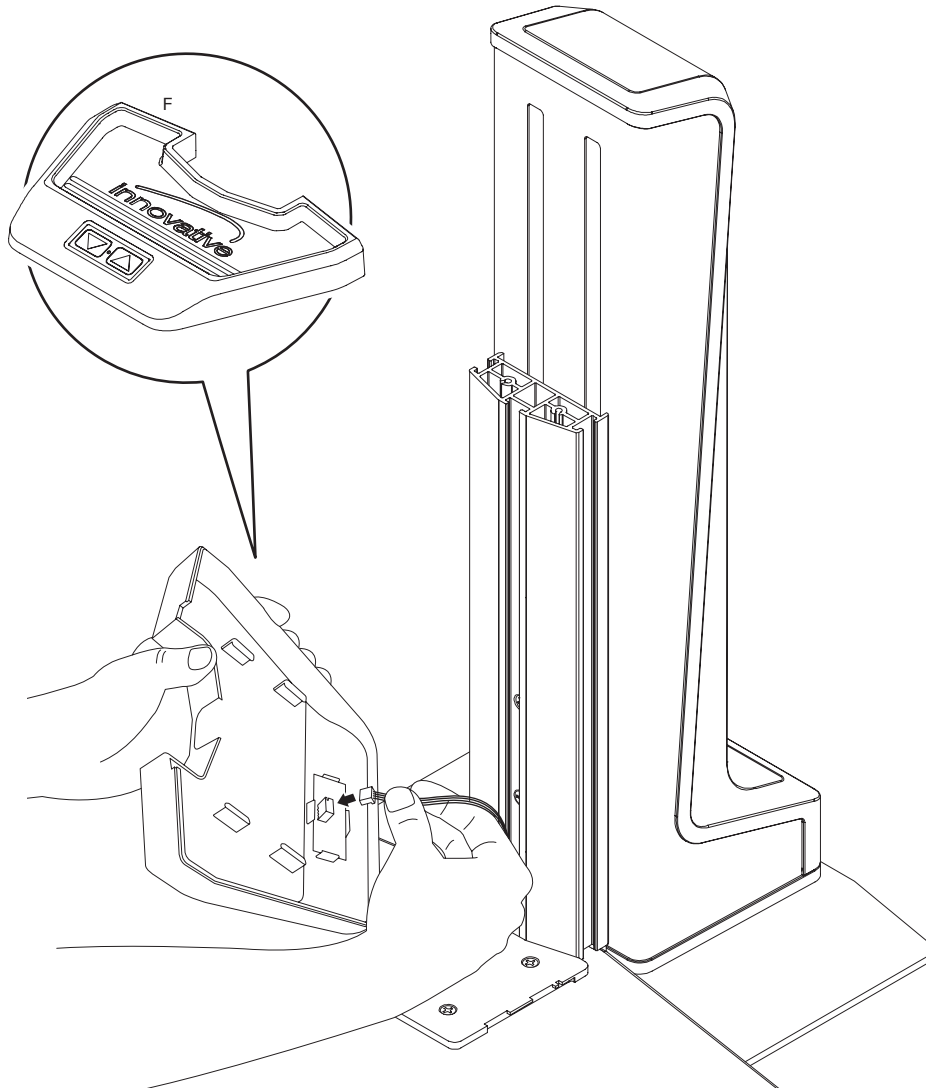

4

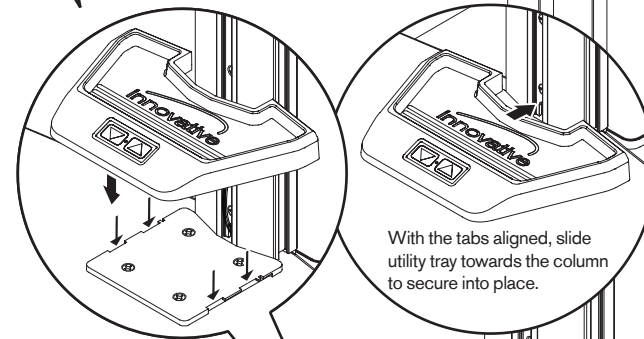
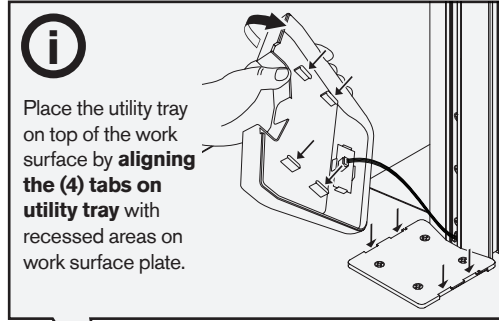

With the tabs aligned, slide utility tray towards the column to secure into place.

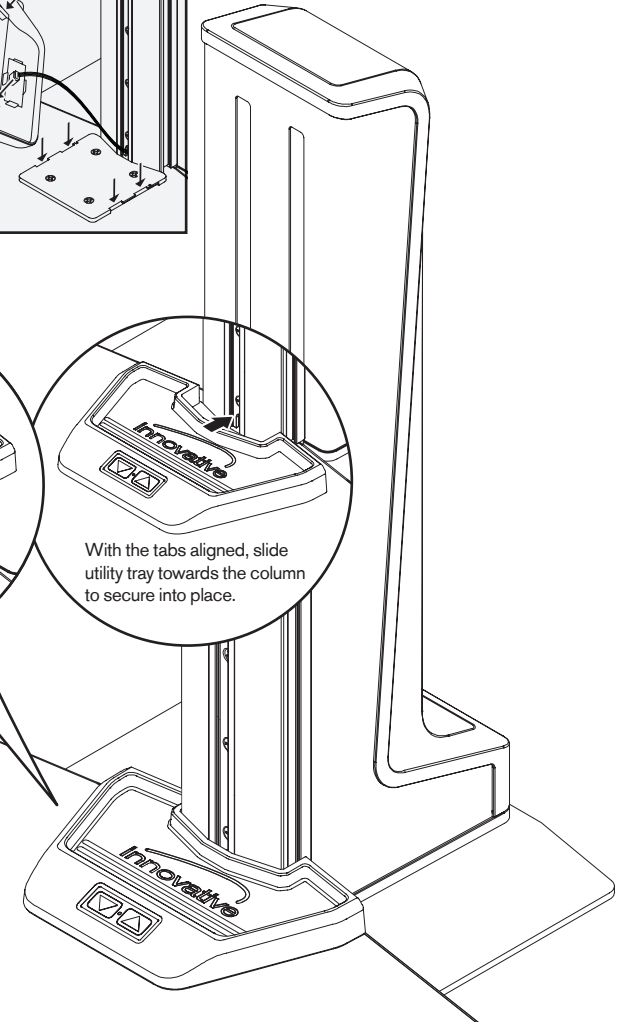

# STEP 3

# WINGS

1

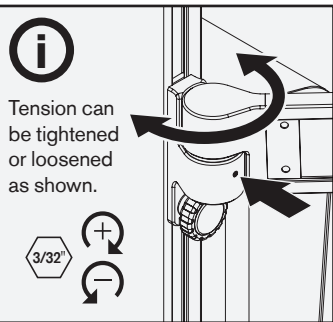
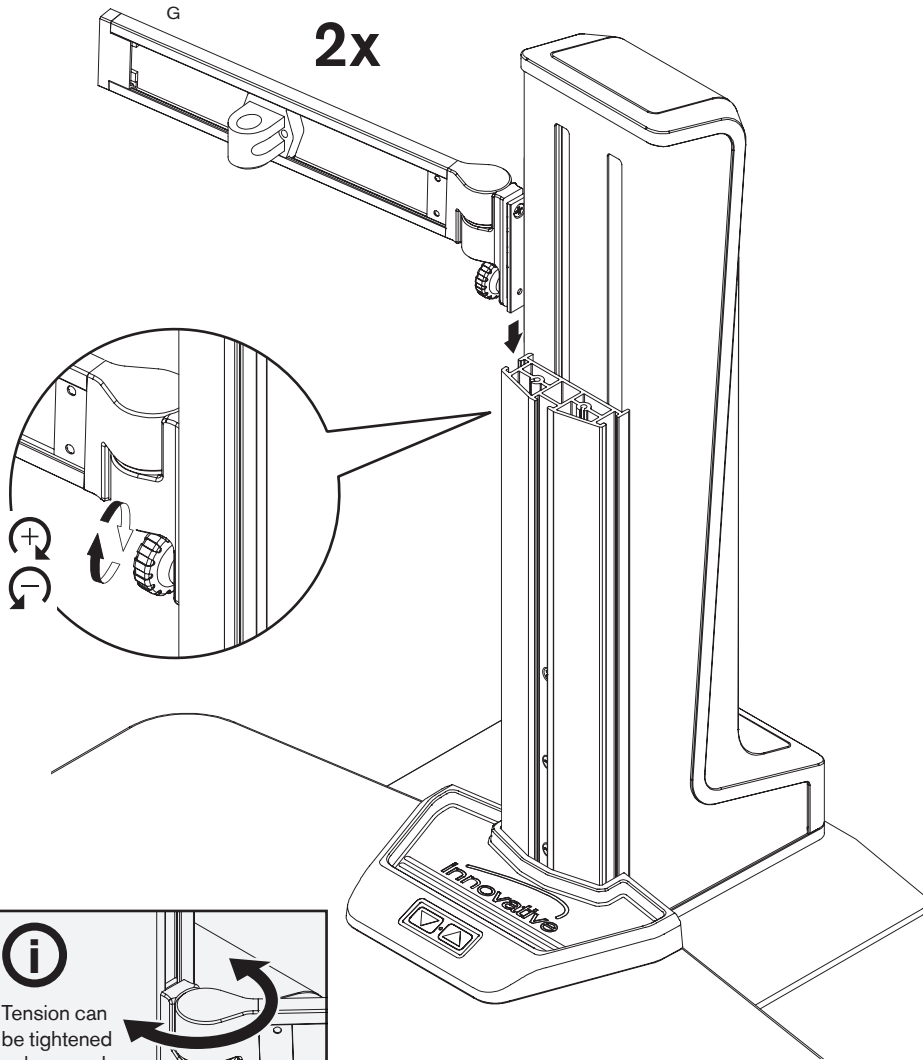

2

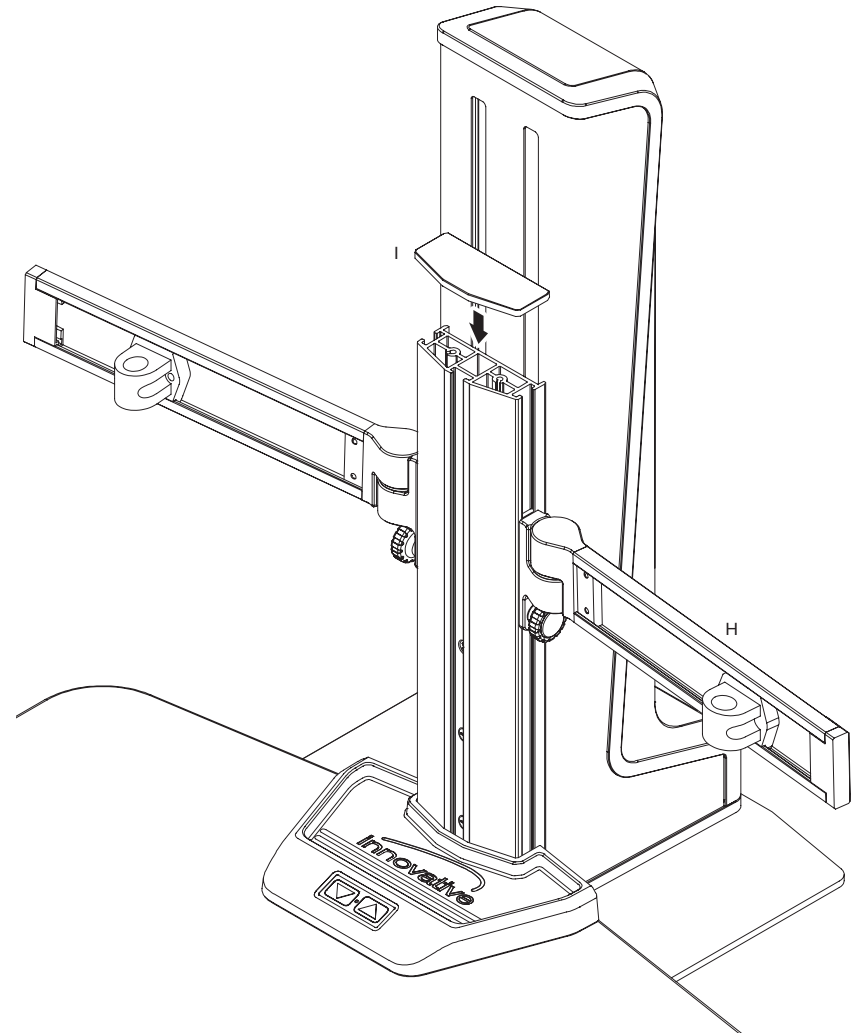

# STEP 4

# MONITOR TILTER

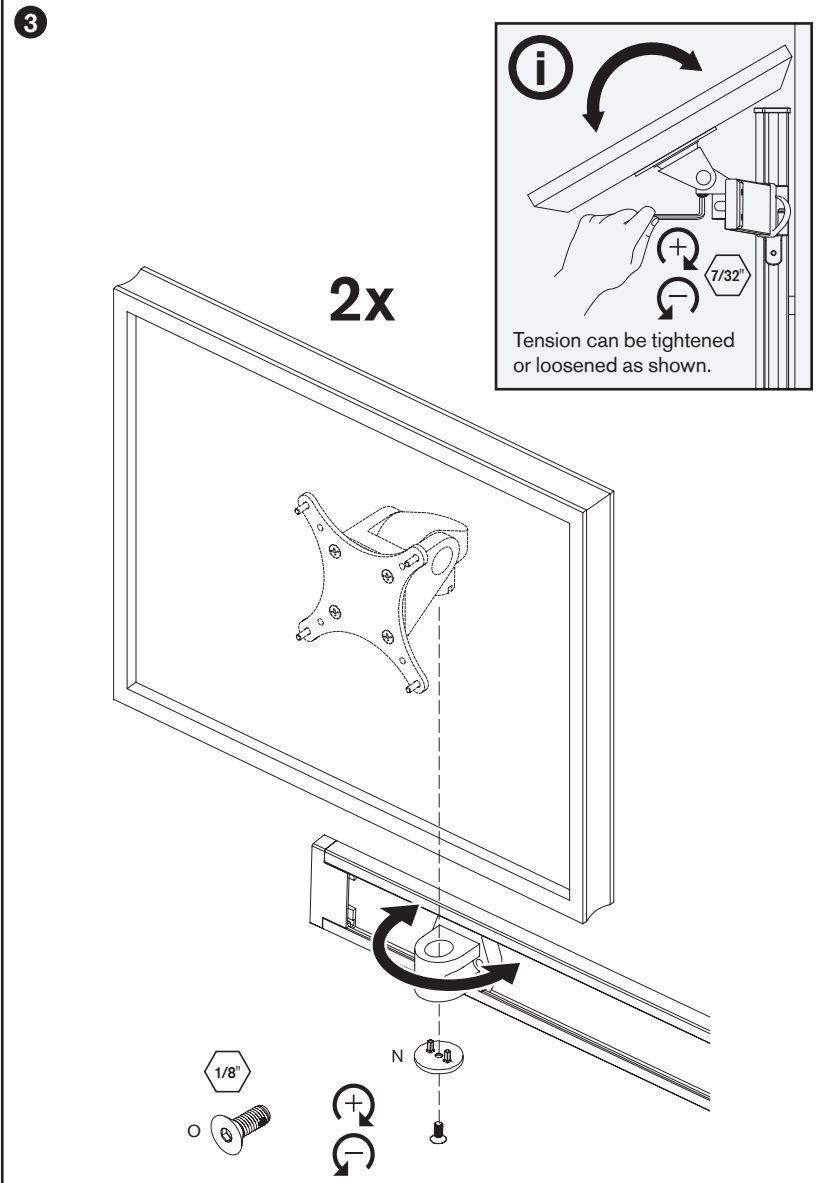
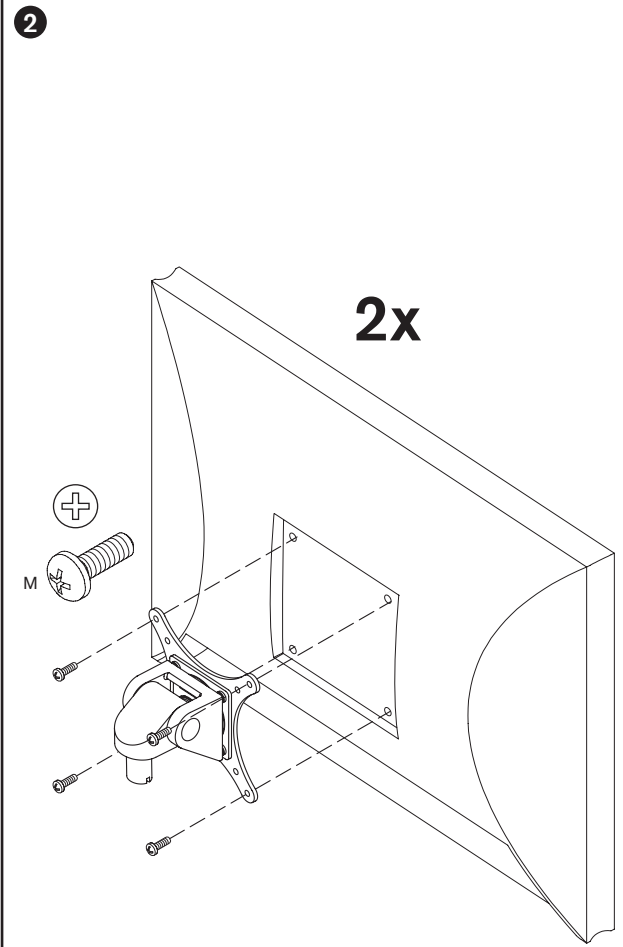
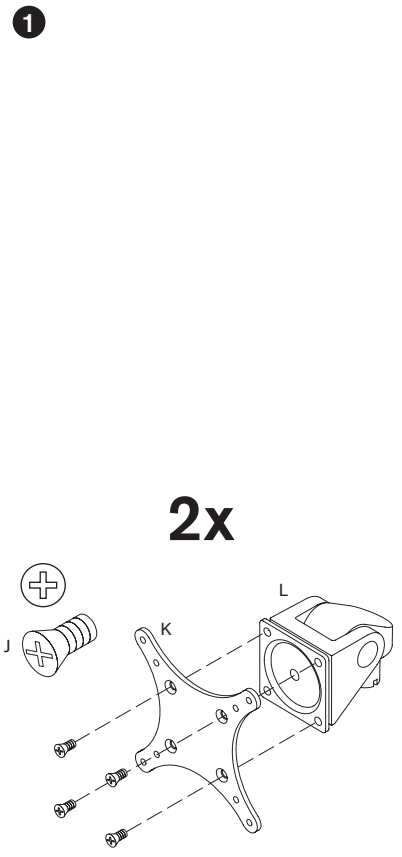



# STEP 5

# CABLE MANAGEMENT

1

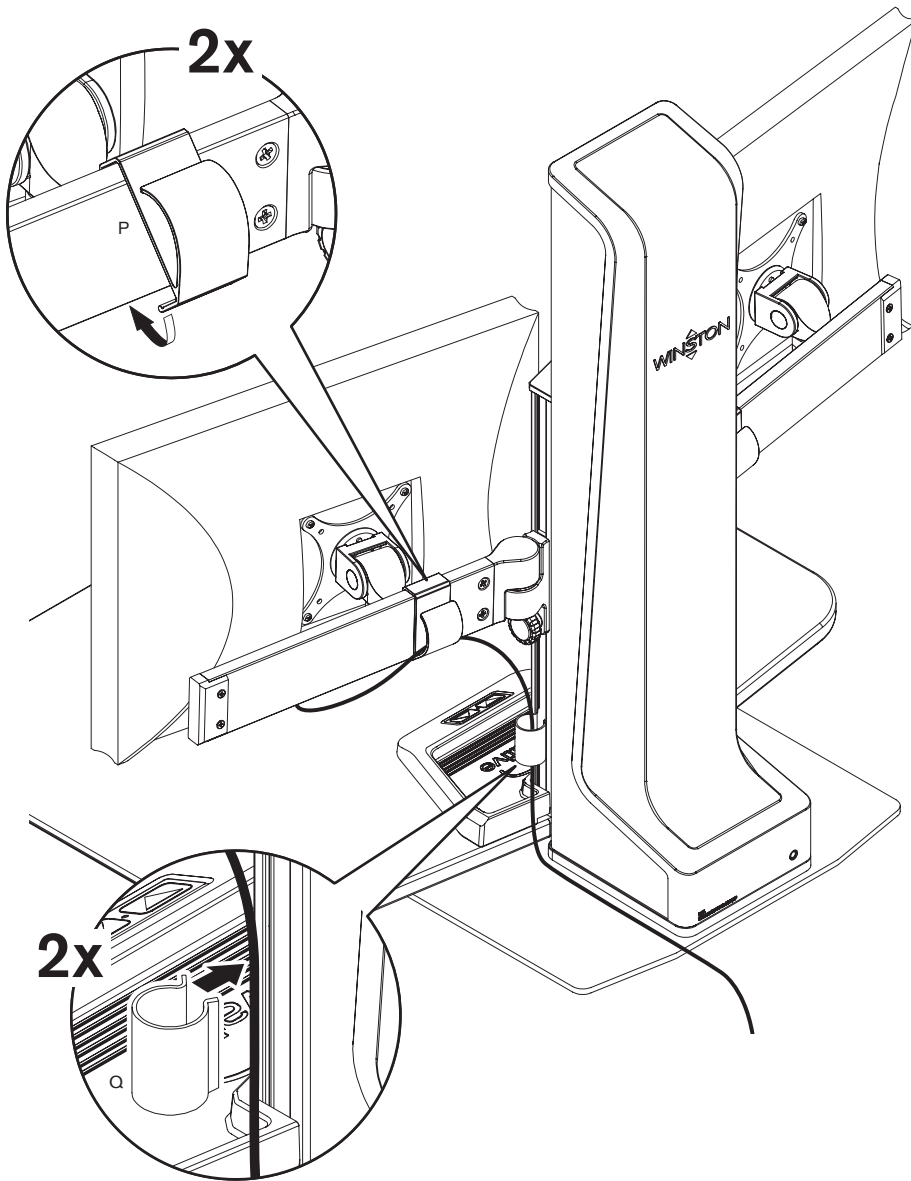

2

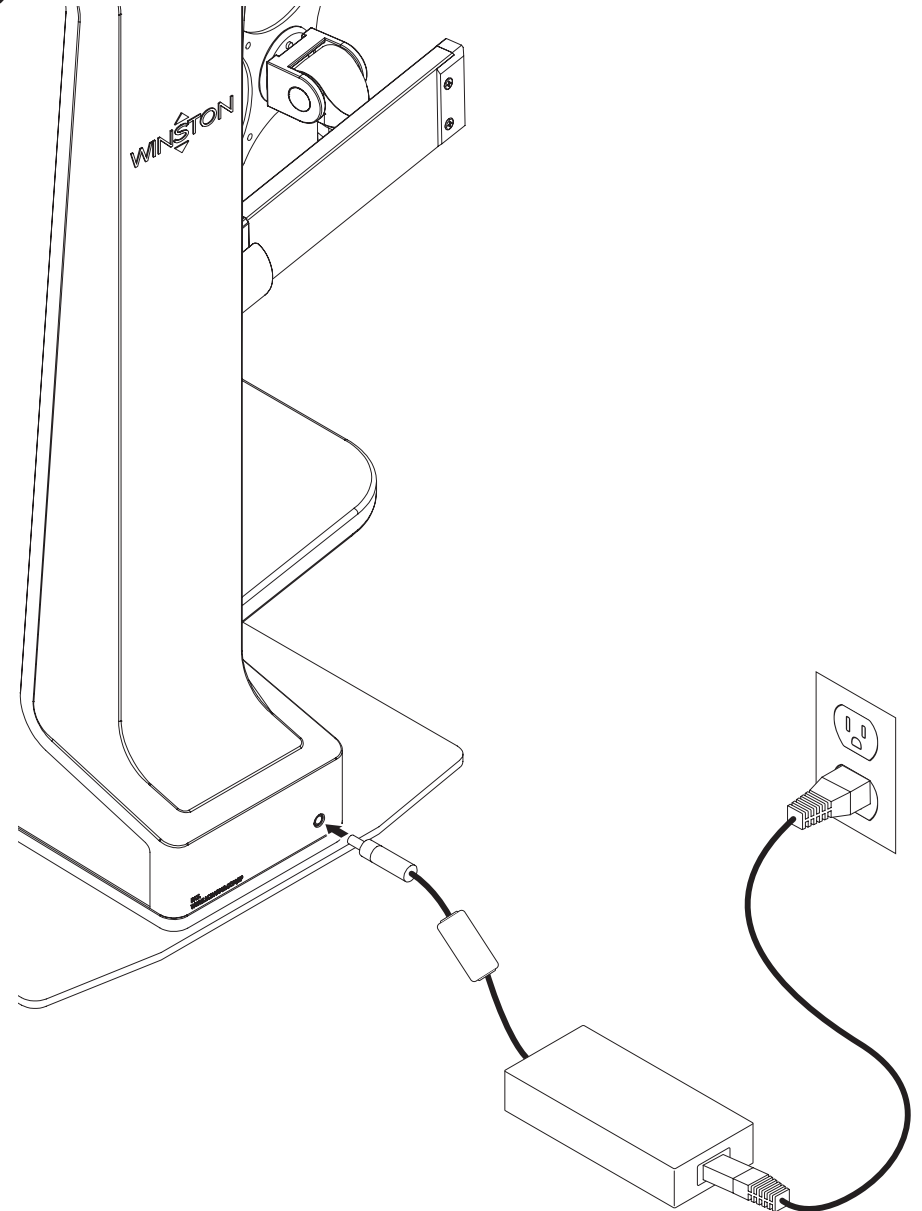

# STEP 6

# BUTTON PROGRAMMING

## HOW TO PROGRAM

**1**

With work surface at its lowest position, **press up button and release.**



**2**

**Press up or down button** to stop the work surface at desired height.



**3**

Wait several seconds for light to blink. While light is blinking, **press up and down buttons at the same time and release.**



**Your Winston-E is now programmed!**

Next time the up button is pressed, the work surface will rise and automatically stop at your preset height.

*To reprogram your single-touch height adjust setting, you will first need to erase the programmed setting (see below).*

## HOW TO ERASE

**1**

With work surface at its lowest position, **press and hold down button for three seconds.** Light will blink to confirm setting has been erased.



**Your Winston-E height adjust setting has been erased!**

To reprogram the single-touch height adjust setting, follow the steps "How to Program" above.