

ATTENTION

IMPORTANT ADDENDUM FOR Rubberwood Desktop UPLIFT Desk assembly

As you assemble your desk, before you move forward with **Page 5 Step I** of your instructions, please read and understand this addendum.

When lining up your Frame with the holes on your Rubberwood desktop, first start the Machine screws for the Side brackets. (three per Side bracket)

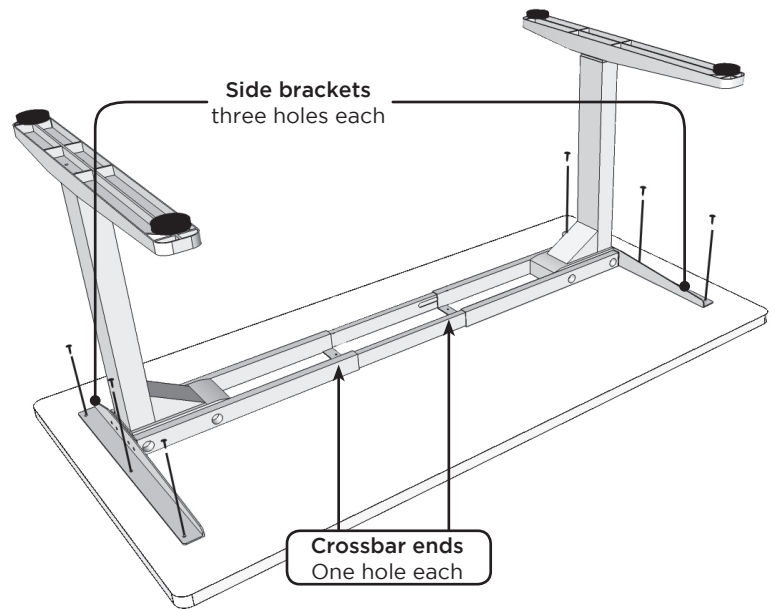

Note: Rotate the Machine screws **only a few turns each**. Do not tighten fully until later.

After the screws for the side-bracket are started, you may notice the holes of the Crossbar Ends may be slightly off due to minor wood imperfections. To rectify this, simply grasp the Crossbar end and pull slightly until the holes line up, and start the Machine screw into this hole

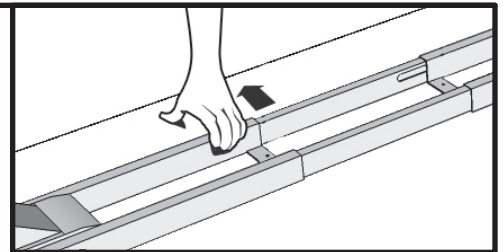

Once all screws are started, you can now tighten all of the Machine screws, and secure the center rails using the M6x10 Machine screws. Resume your desk instructions from here!

UPLIFT DESK®



10017144 - THS605
Rubberwood Instructions