

UPLIFT V2 L-Shaped Standing Desk Frame

SKU: FRMA-3

Specifications

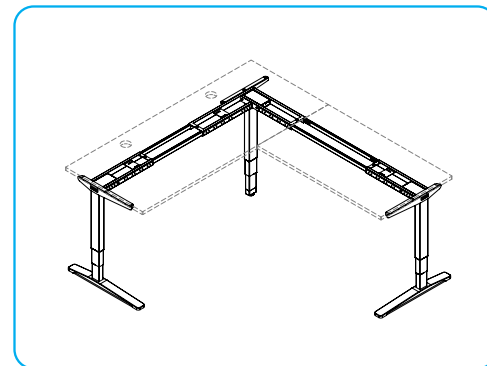
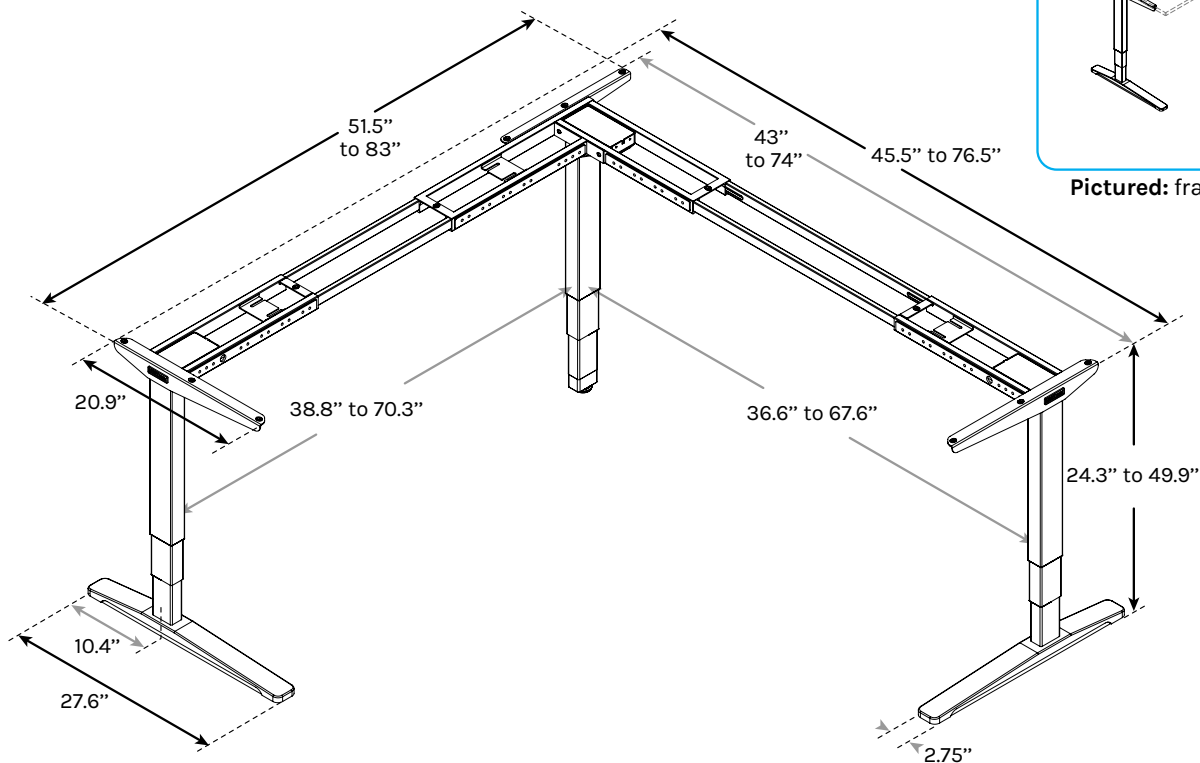

Pictured: frame and desktop placement



**Contract-grade
Quality**

Height Range	24.3"-49.9"
Travel Speed	1.57"/second
Noise Level	50 dB
Lifting Capacity	535 lbs
Current	5 amps max (during movement)
Voltage Input	100-120Vac, 50/60Hz, 500W max
Warranty	15 year



Triple Motor Design



**3-Stage Legs Are 33%
Faster Than 2-Stage Legs**



**Superior Anti-Collision
Sensitivity**



**88 Accessory
Mounting Points**



**Stability Brace
on Each Leg**



**Improved Stability
with Precision
Tolerance Legs**



**Whisper-Quiet
Adjustment**



**Included Under-Desk
Wire Management**



**Available in 4 Color
Options**



**Meets BIFMA X5.5-2014
Durability Standard**



For help with assembly, see our assembly video at upliftdesk.com/3leg-srd-lshp

For technical questions and support call 800-349-3839, email info@upliftdesk.com, or visit our chat service at upliftdesk.com

UPLIFT V2 Curved Corner Standing Desk Frame

SKU: FRMA-3

Specifications

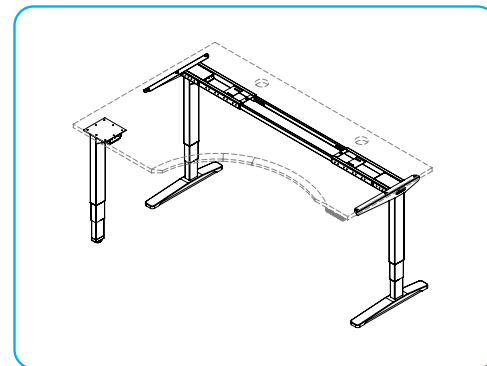
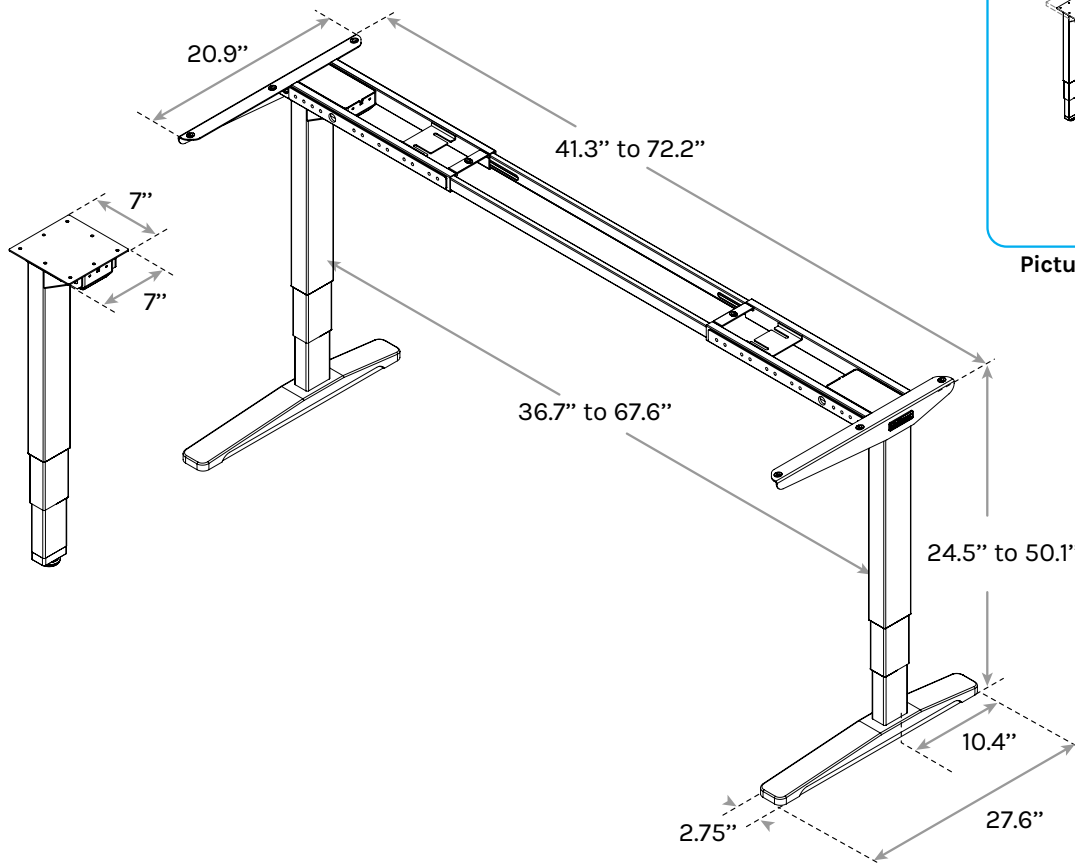

Pictured: frame and desktop placement



**Contract-grade
Quality**

Height Range	24.5"-50.1"
Travel Speed	1.57"/second
Noise Level	50 dB
Lifting Capacity	535 lbs
Current	5 amps max (during movement)
Voltage Input	100-120Vac, 50/60Hz, 500W max
Warranty	15 year



Triple Motor Design



**3-Stage Legs Are 33%
Faster Than 2-Stage Legs**



**Superior Anti-Collision
Sensitivity**



**48 Accessory
Mounting Points**



**Stability Brace
on Each Leg**



**Improved Stability
with Precision
Tolerance Legs**



**Whisper-Quiet
Adjustment**



**Included Under-Desk
Wire Management**



**Available in 4 Color
Options**



**Meets BIFMA X5.5-2014
Durability Standard**



For help with assembly, see our assembly video at upliftdesk.com/3leg-srd-lcor

For technical questions and support call 800-349-3839, email info@upliftdesk.com, or visit our chat service at upliftdesk.com