

UPLIFT 4 LEG DESK FRAME

UPLIFT DESK®

FRM400

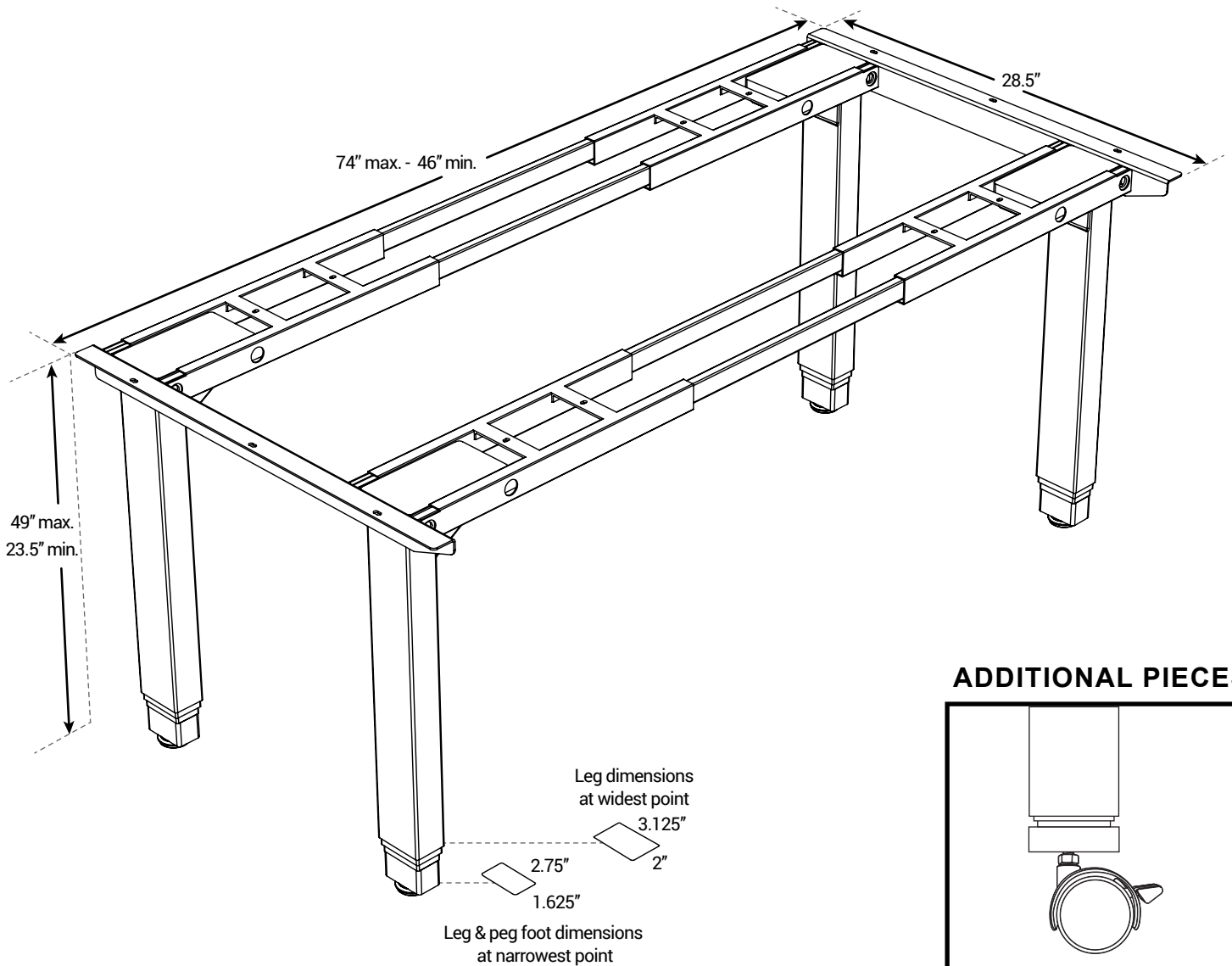

ADDITIONAL PIECES

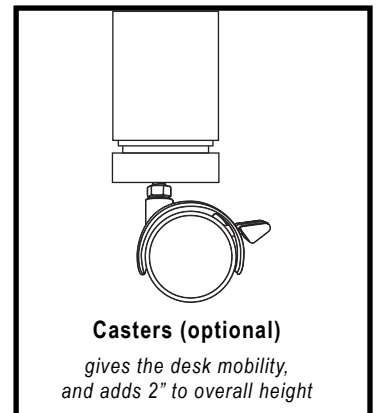

CAPABILITIES

| | |
|---------------------------------|---|
| Travel Speed | 1.5"/second (varies depending on load) |
| Weight Capacity | 530 lbs. |
| Noise Level | 50 decibels during motion |
| Adjustable Foot Levelers | 3/8" adjustment for uneven flooring |
| Voltage | Input: 120V Output: 30Vdc |
| Warranty | 7-year All-Inclusive warranty (includes motor, frame, controller, keypad, electronics & mechanisms) |

FEATURES

- Features 25.5" of height adjustment, a quiet soft start and stop motor in each leg, and an energy saving low-draw transformer that doesn't use much electricity when not lifting or lowering the desk (this Green feature is not found on many other desks).
- Adjustable width telescoping base allows you to perfectly fit the base to your desktop and workspace
- Choose a standard push and hold up/down keypad, or upgrade to the advanced 1-touch digital memory keypad, featuring four programmable presets and an LED desk height readout in inches