

UPLIFT V2 Curved Corner Standing Desk Frame

SKU: FRMA-3

Specifications

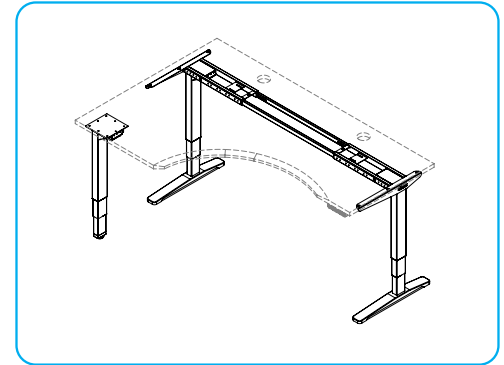
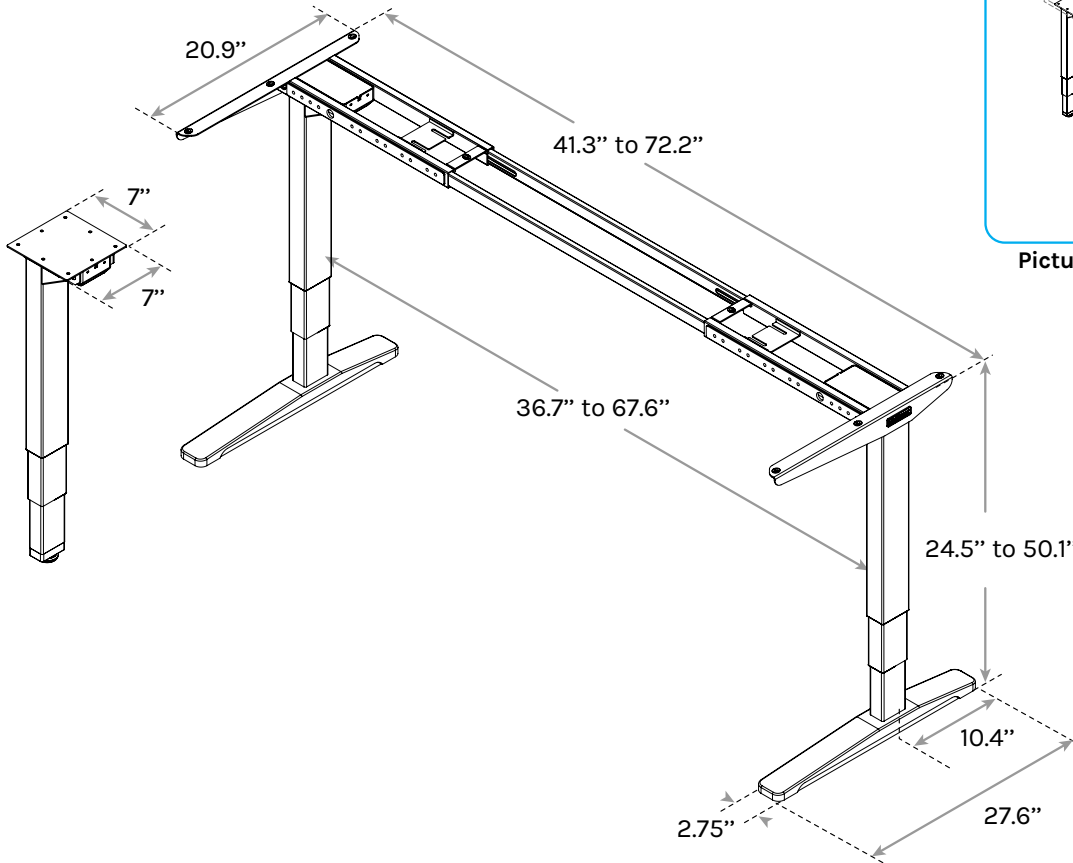

Pictured: frame and desktop placement



Contract-grade Quality

Height Range	24.5"-50.1"
Travel Speed	1.57"/second
Noise Level	50 dB
Lifting Capacity	535 lbs
Current	5 amps max (during movement)
Voltage Input	100-120Vac, 50/60Hz, 500W max
Warranty	15 year



Triple Motor Design



3-Stage Legs Are 33% Faster Than 2-Stage Legs



Superior Anti-Collision Sensitivity



48 Accessory Mounting Points



Stability Brace on Each Leg



Improved Stability with Precision Tolerance Legs



Whisper-Quiet Adjustment



Included Under-Desk Wire Management



Available in 4 Color Options



Meets BIFMA X5.5-2014 Durability Standard



For help with assembly, see our assembly video at upliftdesk.com/3leg-srd-lcor

For technical questions and support call 800-349-3839, email info@upliftdesk.com, or visit our chat service at upliftdesk.com