

UPLIFT 4 LEG DESK FRAME

UPLIFT DESK®

FRM400

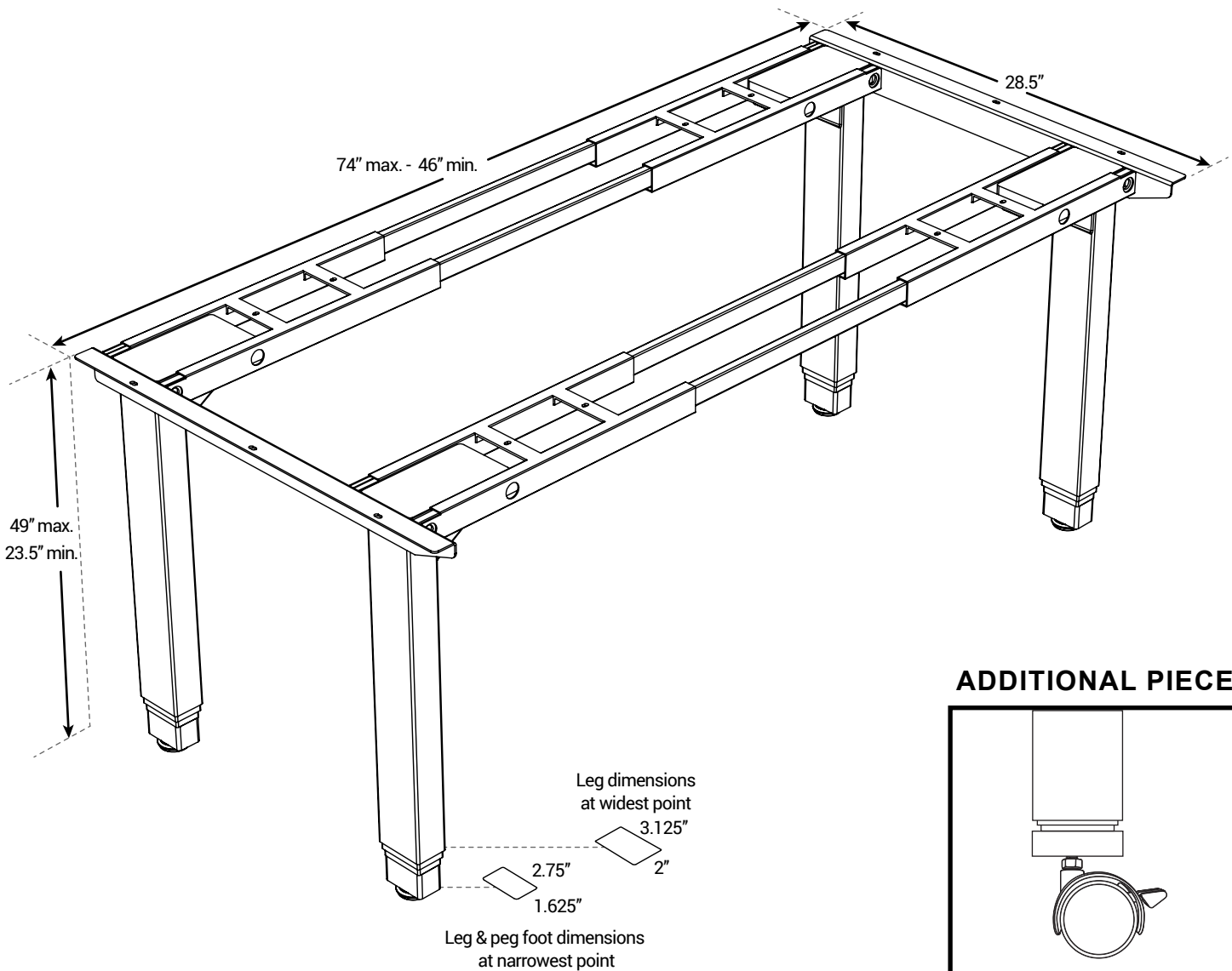

ADDITIONAL PIECES

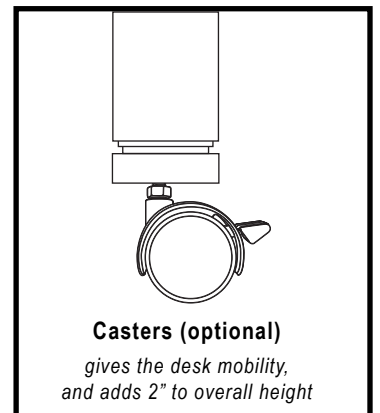

CAPABILITIES

Travel Speed	1.5"/second (varies depending on load)
Weight Capacity	530 lbs.
Noise Level	50 decibels during motion
Adjustable Foot Levelers	3/8" adjustment for uneven flooring
Voltage	Input: 120V Output: 30Vdc
Color	Black, Metallic, Gray, White
Warranty	7-year All-Inclusive warranty (includes motor, frame, controller, keypad, electronics & mechanisms)

FEATURES

- Features 25.5" of height adjustment, a quiet soft start and stop motor in each leg, and an energy saving low-draw transformer that doesn't use much electricity when not lifting or lowering the desk (this Green feature is not found on many other desks).
- Adjustable width telescoping base allows you to perfectly fit the base to your desktop and workspace
- Choose a standard push and hold up/down keypad, or upgrade to the advanced 1-touch digital memory keypad, featuring four programmable presets and an LED desk height readout in inches