

# UPLIFT DESK<sup>®</sup>

## L-SHAPED LAMINATE SIZE



A

All tops are made with two pieces: the large main desk and a smaller piece called the return. You'll use the included connecting hardware during assembly for a secure fit, and include the frame crossbar piece beneath the two desktop sections.

The measurements are as follows:

**A x B x C x D**

- A - Outside Width (60", 72", 80")
- B - Outside Depth (72", 78")
- C - Main Depth (30")
- D - Return Depth (30")

C



B



D

This will come in 6 possible combinations

60x72x30x30

A



C

B



D

72x72x30x30

A



C

B



D

# UPLIFT DESK<sup>®</sup> L-SHAPED LAMINATE SIZE

80x72x30x30  
A

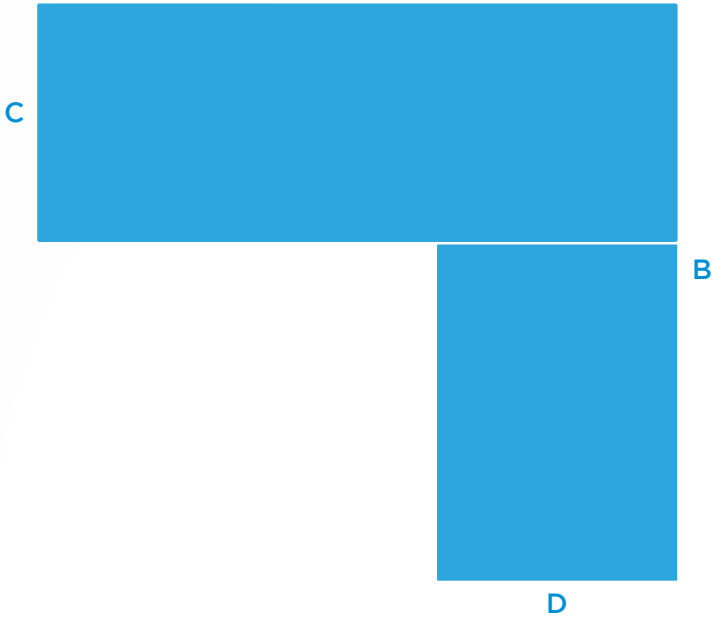

60x78x30x30  
A

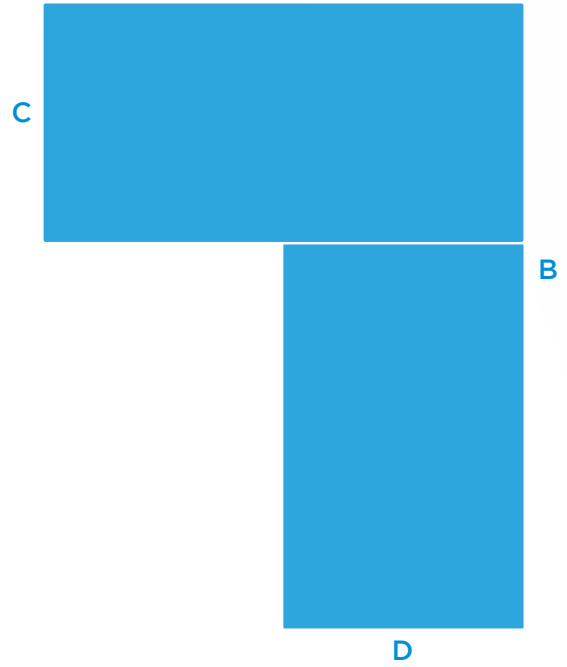

72x78x30x30  
A

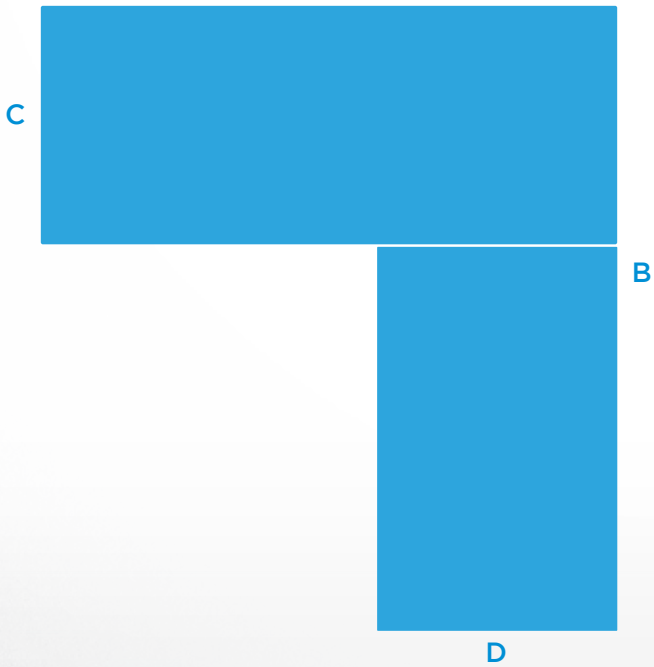

80x78x30x30  
A

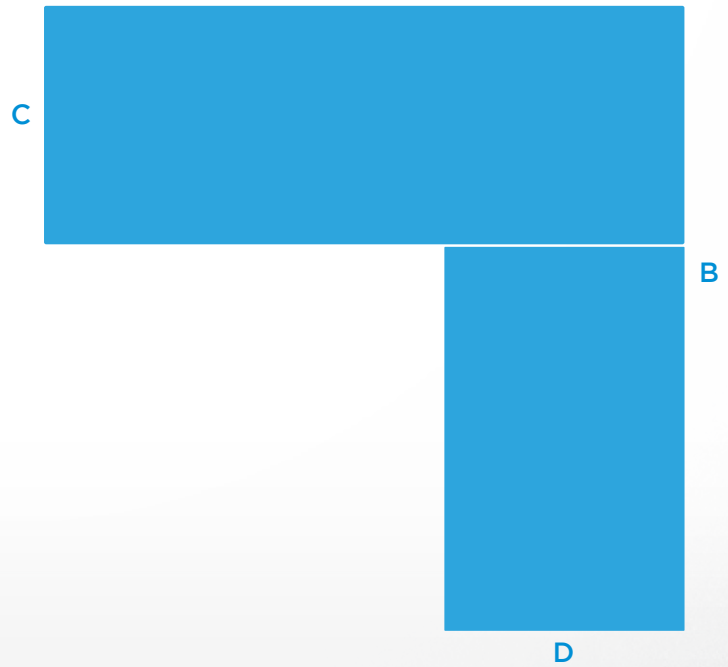

# UPLIFT DESK® L-SHAPED LAMINATE SIZE

## Adding a Treadmill

If you plan to add a treadmill to your L-shaped workstation, quite a bit of additional space is required. In order to provide room for a chair at the inside of your desk, you'll need to place your treadmill on the outside. You will also need a monitor arm for this configuration:

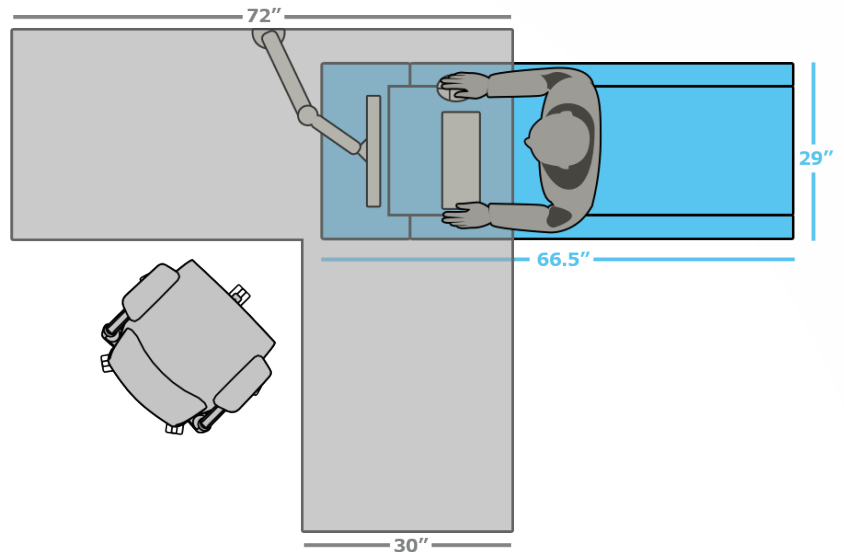

Desk frames feature a telescoping crossbar that accommodates a variety of desktop sizes. If you change from a smaller to a larger top in the future, or vice versa, no problem. UPLIFT will stick with you for years to come!

60x72x30x30

80x78x30x30

