

# UPLIFT DESK<sup>®</sup> Horizon™ Dual Monitor Arm Instructions ACC305

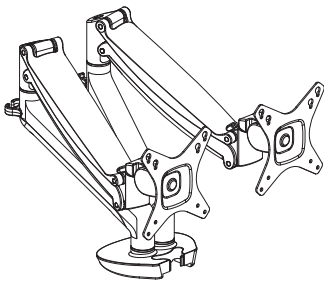

Part 1  
UPLIFT Horizon™ Dual Arm

- |  |                                    |  |                                   |  |                            |  |                            |
|--|------------------------------------|--|-----------------------------------|--|----------------------------|--|----------------------------|
|  | Part 2<br>M4*12 screw<br>(qty 8)   |  | Part 7<br>Allen wrench<br>(large) |  | Part 11<br>Clamp bracket   |  | Part 16<br>Bolt plate      |
|  | Part 3<br>Washer<br>(qty 4)        |  | Part 8<br>Boxed wrench            |  | Part 12<br>Clamp plate     |  | Part 17<br>Bolt assembly   |
|  | Part 4<br>M6*12 screw<br>(qty 3)   |  | Part 9<br>Cable cover 1           |  | Part 13<br>Clamp bolt      |  | Part 18<br>Open-end wrench |
|  | Part 5<br>Allen wrench<br>(small)  |  | Part 10<br>Cable cover 2          |  | Part 14<br>Outer wire clip |  | Part 19<br>Nut             |
|  | Part 6<br>Allen wrench<br>(medium) |  |                                   |  | Part 15<br>Clamp gasket    |  | Part 20<br>Inner wire clip |
|  |                                    |  |                                   |  |                            |  | Part 21<br>Bolt gasket     |

## Step 1

Attach Monitor Arm to desktop.

There are two ways to attach your UPLIFT Horizon™ Dual Monitor Arm to your desktop: Clamp and Bolt-through assembly.

### Clamp Assembly - Attach the arm to the back of the desk. Clamp will fit desks up to 1.7"

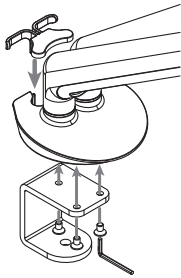

#### Clamp Step 1

Slide the Outer wire clip (part 14) into the back notch of the Arm's base. Attach the Clamp bracket (part 11) to the Arm's base with three M6\*12 screws (part 4). Secure the screws with the medium Allen wrench (part 6).

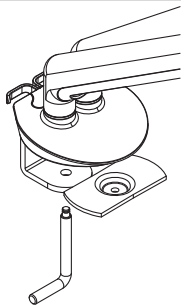

#### Clamp Step 2

Screw the Clamp bolt (part 13) up from the bottom of the Clamp bracket, and insert the Clamp plate (part 12) into the tab at the tip of the Clamp bolt.

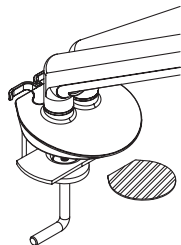

#### Clamp Step 3

Apply the Clamp gasket (part 15) under the Arm's base. Match the holes in the gasket to where the placement of the screws are.

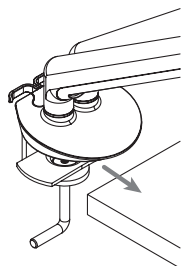

#### Clamp Step 4

Slide the assembly onto your desk, and turn the Clamp bolt to tighten and affix to desk.

**Bolt-Through Assembly - Will work with holes from .4" to 3.14" in diameter, and desks up to 2" thick.**

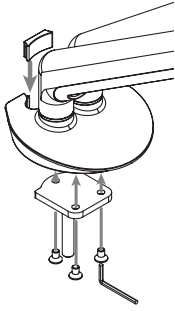

**Bolt-Through Step 1**

Slide the Inner wire clip (part 20) into the back notch of the Arm's base. Next, take the Bolt assembly (part 17) and attach it to the underside of the Arm's base with the three M6\*12 screws (part 4), and tighten with the medium Allen wrench (part 6).

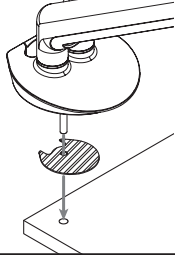

**Bolt-Through Step 2**

Apply the Bolt gasket (part 21) under the Arm's base, sliding the bolt through the gasket's center hole.

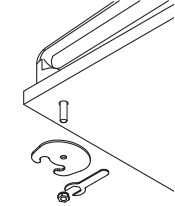

**Bolt-Through Step 3**

On the underside of the desk, place the Bolt plate (part 16) around the bolt, and screw on the Nut (part 19). Use the Open-end wrench (part 18) to tighten and secure the Monitor arm.

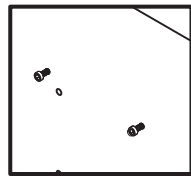
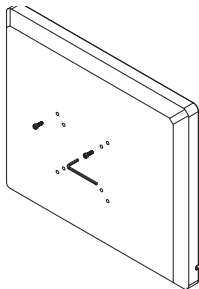

Fig. 1

**Step 2**

Use the small Allen wrench (part 5) to insert two M4\*12 screws (part 2) into the top two holes on the back of your monitor (see figure 1).

Do not screw them in all the way. Leave some space as shown.

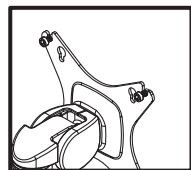
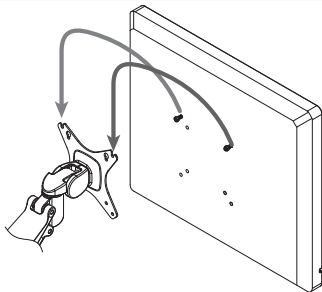

Fig. 2

**Step 3**

Place the monitor onto the open holes on the VESA plate on the arm. See figure 2 for specific placement. Let the monitor hang from the two screws.

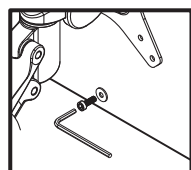
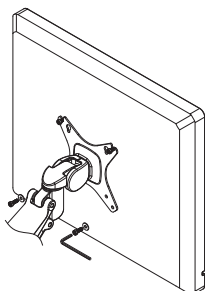
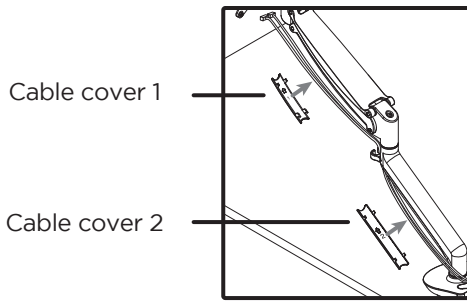

Fig. 3

**Step 4**

Screw in two M4\*12 screws (part 2) and two washers (part 3), into the lower holes on the VESA mounting plate (see figure 3) and tighten. When finished, tighten all screws from step 2.

Repeat steps 2-4 with your second monitor.



### Step 5

Plug your cables into your monitor. Use the Cable covers (parts 9 & 10) to hold the monitor's cables along the underside of the arm. Use Cable cover 1 (part 9) on the upper part of the arm, and Cable cover 2 (part 10) on the lower part of the arm.

Leave some slack in the cables near the joints to allow the arm room to adjust.

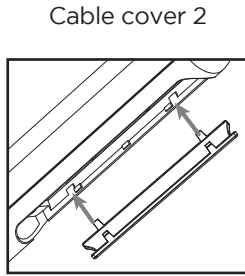
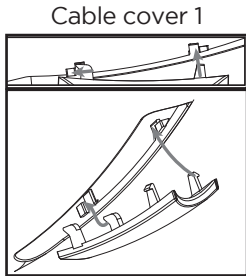

Refer to the illustrations to the left to complete the installation of Cable cover 1 and Cable cover 2. Both covers should be completely secure before moving on to Step 6.

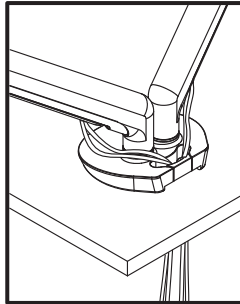
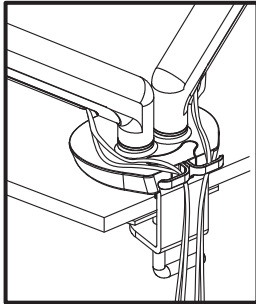

### Step 6

If you attached the arms to your desk using the Clamp method, you can run your wires down the back into the Outer wire clip.

If you attached the arm by the Bolt-through method, and the grommet hole is wide enough, you can run your wires through the Inner wire clip.

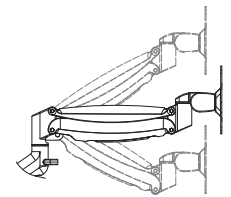
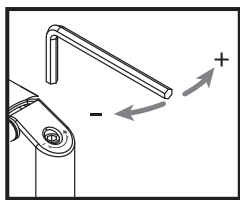
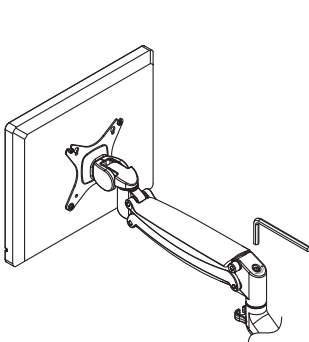

### Step 7

Now that your monitor is attached to the arm, and the arm is on your desk, try moving the monitor around a bit, and then let it go. Does the monitor stay put after you let it go, or does it rise upward or drift down? If so, you may need to adjust the counterbalance.

To adjust counterbalance, use the large Allen wrench (part 7) and insert it into the hex slot at the hinge of the lower and upper arm.

Turning clockwise will reduce the tension for lighter monitors. Turning counterclockwise will increase the tension so the arm can lift heavier monitors more easily. This may take several turns.

The goal is to get the counterbalance positioned to where you can move the monitor to any height, and for the arm to hold it at that placement.

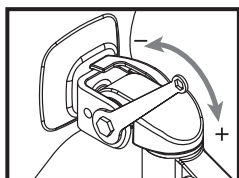
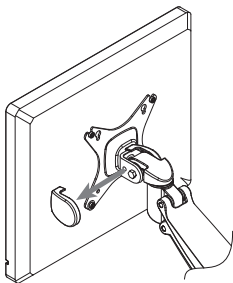

### Step 8

You can adjust the forward and backward tilt of your monitor. First, remove the plastic cover on the VESA mount hinge.

Use the Boxed wrench (Part 8) to adjust the bolt if needed. Loosen it up enough so that you can tilt the monitor downward or upward. When you get it to a position you like, tighten the bolt and replace the plastic cover.

## UPLIFT Horizon™ Dual Monitor Arm adjustability

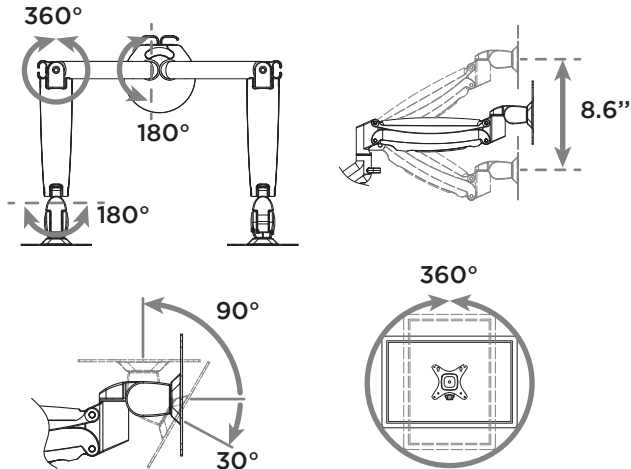

- The maximum load capacity for each UPLIFT Horizon™ monitor arm is 18.7 lbs. **Do not overload.**
- Leave some slack in the cables near the joints of the wire management to allow the arm room to adjust.
- Secure all clamps and mounts to a stable desktop.

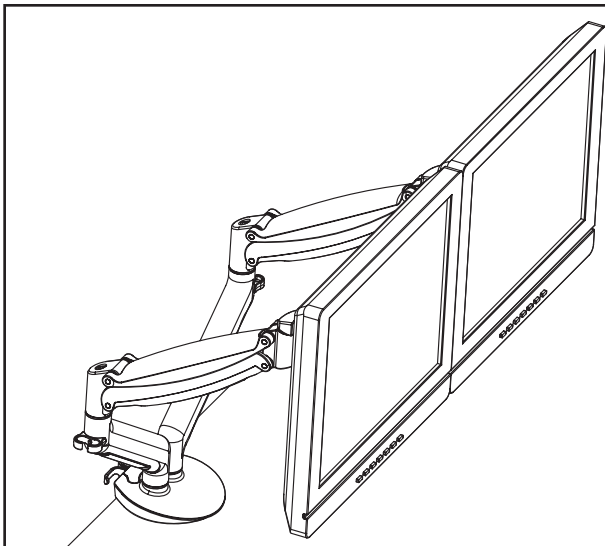

- NOT A CHILD'S TOY. Children under 12 must be supervised by an adult while using UPLIFT Horizon™ Dual Monitor Arm.
- Failing to follow these assembly instructions and safety precautions may result in personal injury.
- Failing to follow these assembly instructions and safety precautions voids your warranty and may result in property damage.

© **Copyright Notice:** These instructions are a component of the UPLIFT Horizon™ Dual Monitor Arm. These instructions are part of the scope of delivery, even if the item is resold. These instructions are also available on the UPLIFT Desk website: [upliftdesk.com](http://upliftdesk.com). Excerpts or copies may not be forwarded to third parties or used in any other published form without the prior written consent of UPLIFT Desk. These instructions are subject to United States copyright law.