

Facet Ergonomic Chair

SKU: CHR466

UPLIFT DESK

Package Contents

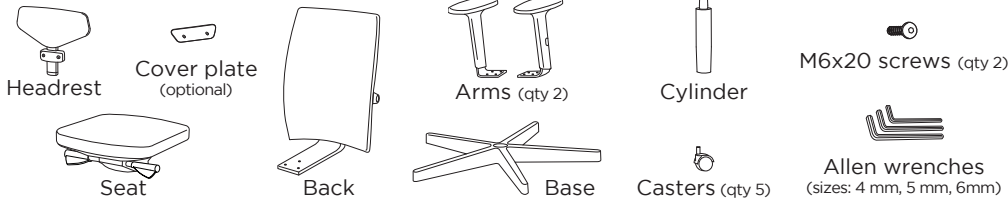

- M6x25 screws (qty 8)
- M6 washers (qty 8)
- Note: may be pre-installed in Chair Seat**
- M8x30 screws (qty 3)
- M8 washers (qty 3)
- Note: may be pre-installed in Chair Back**

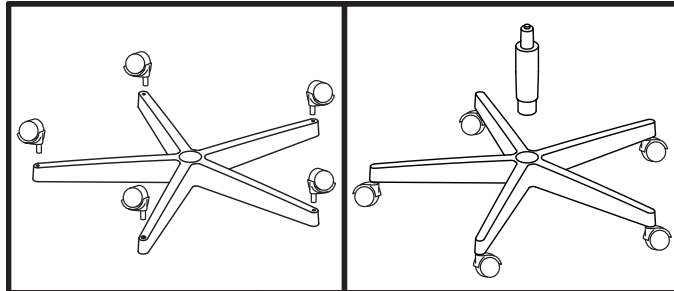

Step 1

With the Base turned upside down, insert the Caster stems into the holes on the Base, and press them firmly to secure them in place.

Flip the Base, so the Casters are on the floor, and insert the Cylinder into the Base in the orientation shown with the smaller diameter end up. Be cautious around the small end of the Cylinder to avoid getting grease on you or your clothes.

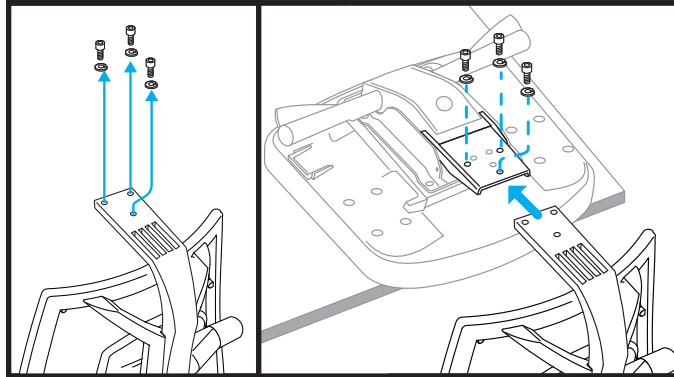

Step 2

Note: The screws and washers may arrive inserted into the Back. Simply remove, and then use to attach the Back to the Seat.

Place the Seat upside down on the edge of a stable surface, such as a table.

Insert the tab of the Back into the slot on the Seat and line up the holes on each. Have a friend help keep the Seat steady while you attach the Back to the Seat with three M8x30 screws and three M8 washers. Start all screws loosely, then tighten them all using the 6 mm Allen wrench.

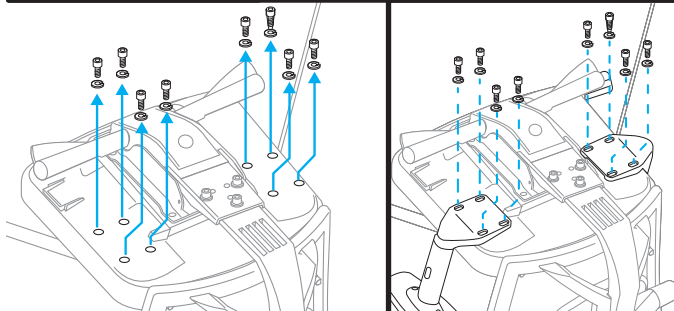

Step 3

Note: The screws and washers may arrive inserted into the Seat. Simply remove, and then use to attach the Arms to the Seat.

Line up each Arm with a set of four holes on either side of the seat. The arms should angle towards the front of the chair when installed. Attach the arms to the seat using the M6x25 screws and M6 washers you removed earlier. Start all screws loosely, then tighten them all using the 5 mm Allen wrench.

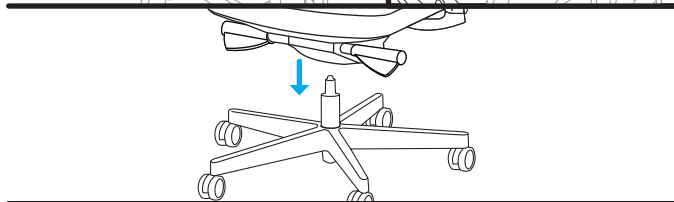

Step 4

Flip the chair assembly from Steps 2 and 3 right-side up, and lower it onto the Cylinder. Press down on the seat (or sit on it) to secure it in place on the Cylinder.

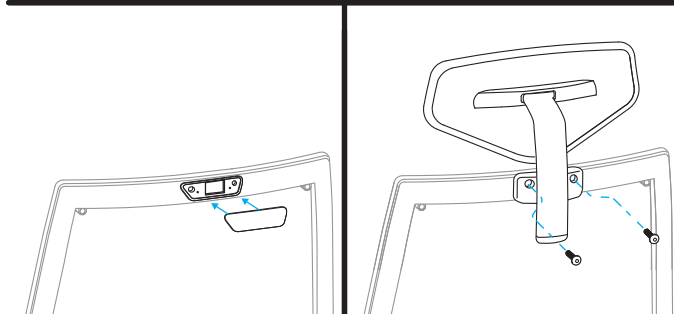

Step 5

If you don't want to install the Headrest, snap the Cover plate in place where shown. This will cover the area where the Headrest would have attached.

If you would like to install the Headrest, line it up with the screw holes at the top of the Back and attach with the two M6x20 screws. Start both screws loosely, then tighten them using the 4 mm Allen wrench.

Adjustment Guide

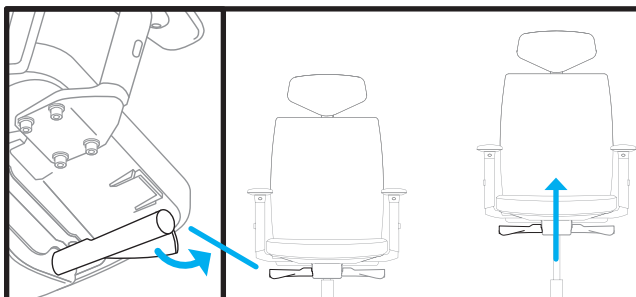

Seat Height

When seated, find the lever on your right-hand side and lift it up to raise or lower the seat.

Your feet should rest flat on the ground. To find your optimal settings, refer to our Ergonomic Calculator:

www.upliftdesk.com/ergonomic-calculator/

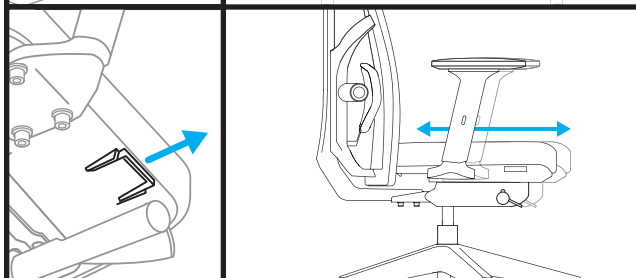

Seat Depth

To change your Seat Depth, unlock the seat position by pulling out the lever located under your seat on the right-hand side. Slide the seat forward or backward as you desire. Release the lever to lock.

To return the seat to the back position, pull the lever out and lift yourself off of the seat. The seat will slide back on its own.

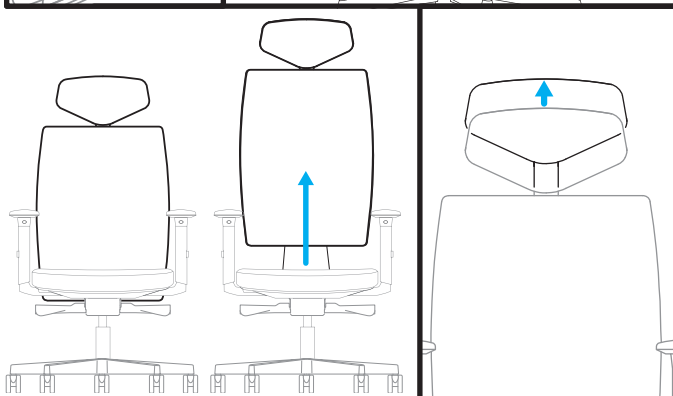

Back & Headrest Height

There are seven height settings for the Back. To raise the Back, grasp it on both sides and pull up, one click at a time, until you reach your desired height. To lower the Back, raise it to the maximum height, then allow it to lower itself down.

Note: If the Back will not lock when returned to the lowest position, pull the seat forward to allow the back to reach its lowest position.

To raise or lower the Headrest, hold both sides and slide up or down to your desired height. This is most easily done while standing behind the chair.

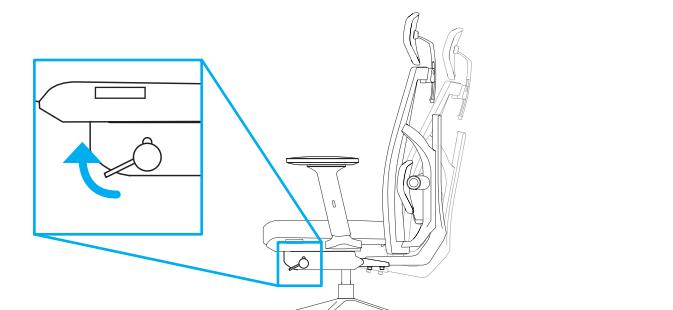

Tilt Lock

Recline to your desired position, then flip the tab on the left side up to lock the recline position.

There are three recline positions for the backrest.

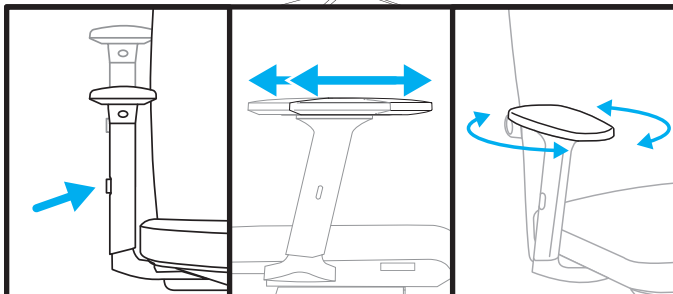

Armrest Adjustments

Height- Press the button on the arm to raise or lower the armrest.

Depth- Grasp armpads and push forwards or backwards to desired placement.

Angle- Grasp armpads and rotate them inwards or outwards to adjust angle.

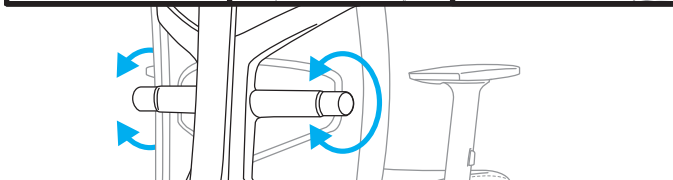

Lumbar Depth

Twist both knobs on the back frame to adjust the depth of the Lumbar support cushion.

*A note about fabric care

Normal- Vacuum your fabric seat as needed. Vacuuming picks up dust and reduces the need for professional cleaning.

Ink Stains- Apply a small amount of isopropyl alcohol to a clean and damp absorbent cloth. Start at the outside of the ink stain and work towards the center. Apply pressure, but do not rub too vigorously. As you work and your cloth soaks up the ink from the fabric stain, it's important to use a clean section of the cloth or the stain will spread. Apply more isopropyl alcohol to the cloth as needed. If the ink stain persists, try using acetone. Note: This procedure is not intended for day-to-day cleaning.

Spot Cleaning- Immediately soak up the stain with a soft, absorbent cloth. Do not dry the stain completely, as this may set it in the fabric permanently. The longer a stain is allowed to remain on the fabric, the more difficult it is to remove.

Oil-based Stains- Use a dry cleaning solution applied with a damp clean cloth or sponge. Test the cleaning solution on a small, concealed spot on the fabric first before attempting on a larger area. If there is no spotting, ringing, or damage to the fabric or its dyes, apply the cleaning solution to the soiled area with light, quick strokes. Begin at the outside of the stain and work towards the middle, making sure you use a clean part of the cloth as you work.

Water-based Stains- Use a water-based fabric cleaner (specifically made for cleaning fabric) or a solution of mild, alkaline, warm soapy water. Make sure that the soap and water mixture is not overly soapy. Test on a small, concealed section of the fabric first before applying to the main area. Work the cleaner or soap/water mixture into the stain on the fabric, starting from the outside of the fabric and working your way to the middle.

CAUTIONS & WARNINGS

- ⚠ CAUTION:** Read all instructions before assembly. Failure to assemble properly may result in damage or personal injury.
- ⚠ WARNING:** This product's maximum weight capacity is 250 lb (113.4 kg). DO NOT exceed the maximum weight capacity.

UPLIFT DESK[®]

Work Better. Live Healthier

512-614-3152

800-349-3839

info@upliftdesk.com

upliftdesk.com



Copyright Notice: This guide is a component of the UPLIFT Facet Chair. This guide is a part of the scope of delivery, even if the item is resold. This guide is also available on the UPLIFT Desk website: upliftdesk.com. Excerpts or copies may not be forwarded to third parties or used in any other published form without the prior written consent of UPLIFT Desk. These instructions are subject to United States copyright law.