

**Product data sheet:
Electric height adjustable desk frame 501-7**

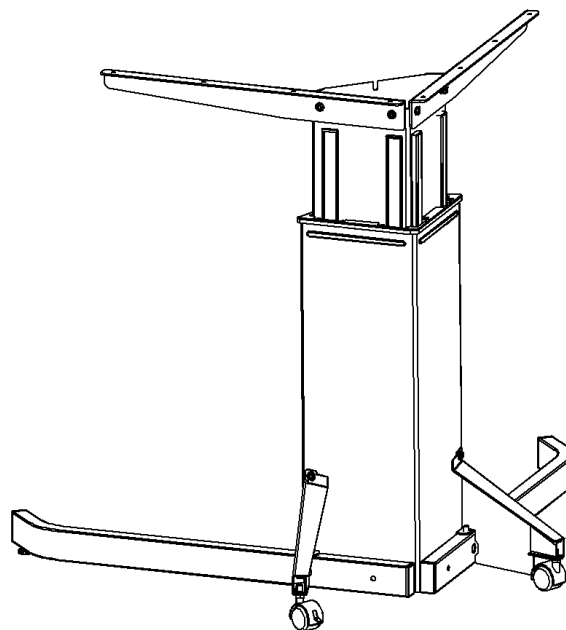
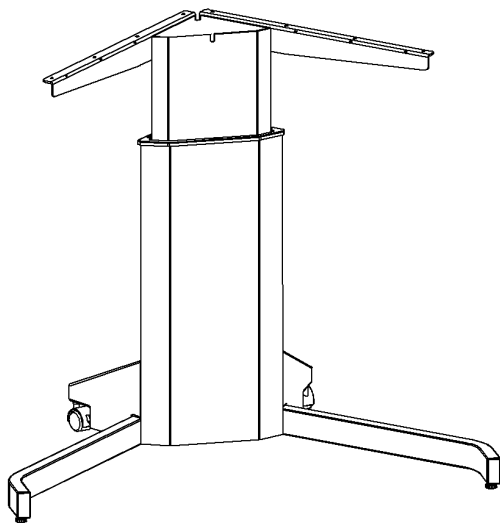
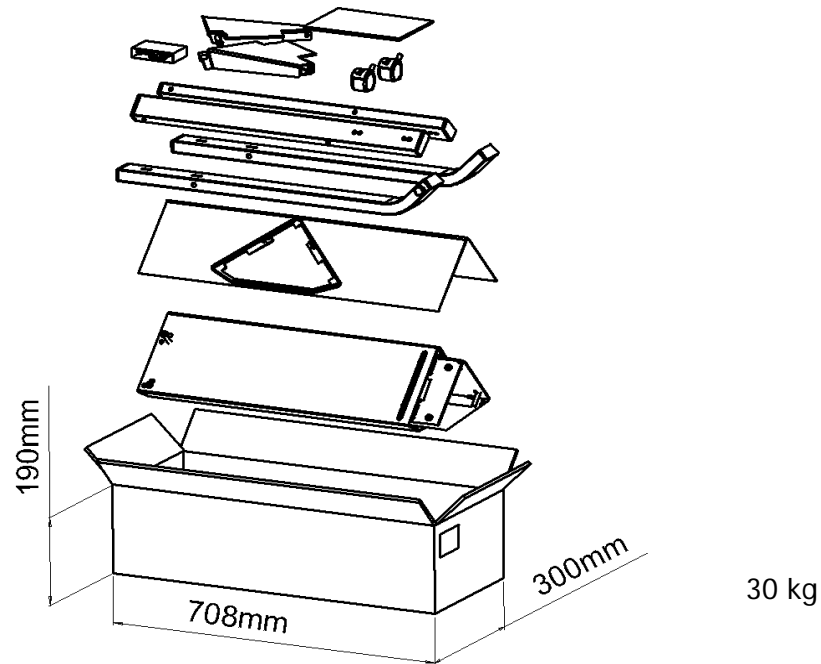

Table of contents

Technical specifications	page 3
Main measures	page 4
Assembly and use	page 5
Performance	page 6
Safety and tests	page 7
Tabletop drilling	page 8
Component specifications	page 9

Technical specifications



	501-7 7X
H [mm]	min. 660; max. 1180
D [mm]	580
W [mm]	925

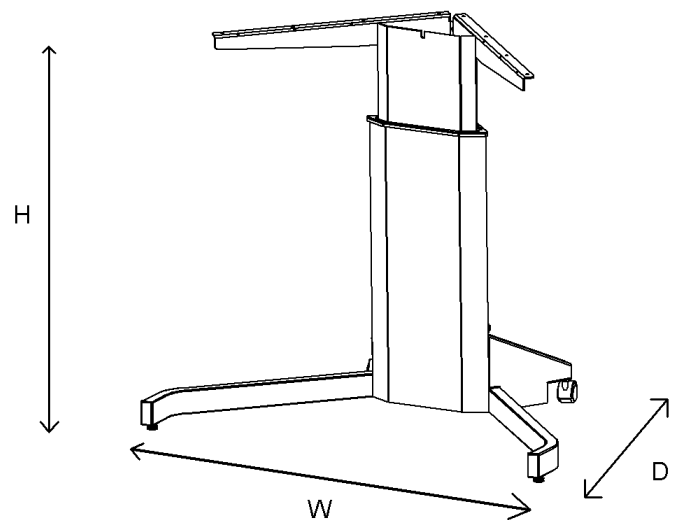

Main measures

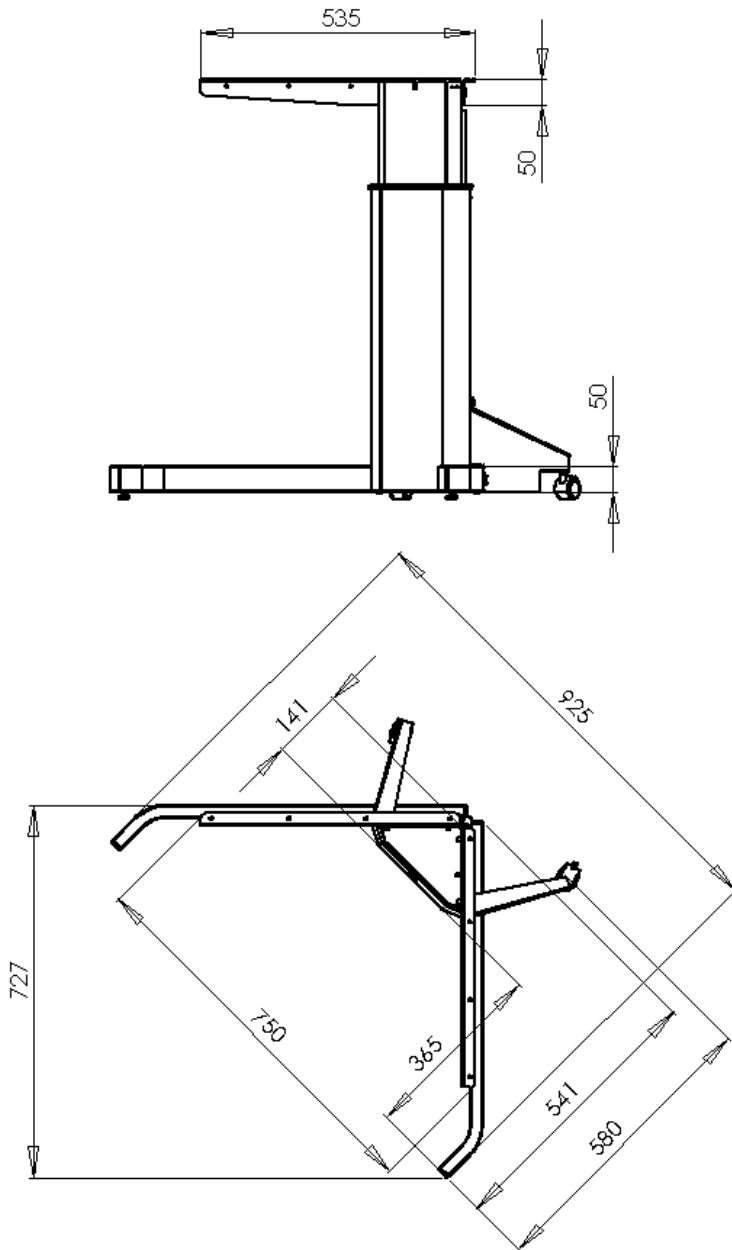

If further documentation needed, please find dwg documentation on the website.

Assembly and use

Along with all products a "Direction for assembly and use" is delivered. In this you will find a detailed description of the way of assembly, please find the sketch below coming from this instruction.

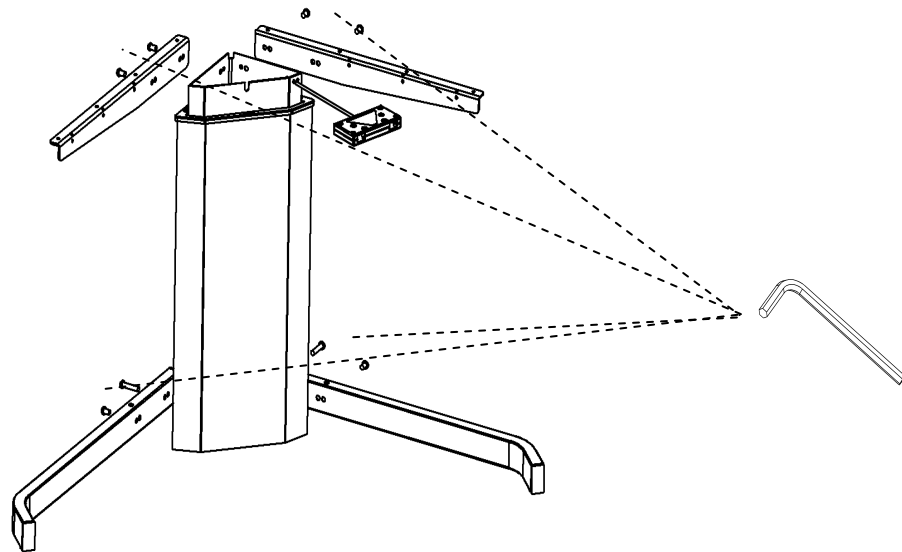

After the frame has been mounted the chosen tabletop is mounted and the operation unit will be possible to fix at the bottom side of the tabletop. This operation unit has two rocker switches.

With rocker switch A and B it is possible to move the tabletop up and down and can be stopped at all levels. For safety reasons it is necessary to push both buttons at the same time for moving the table up and down.

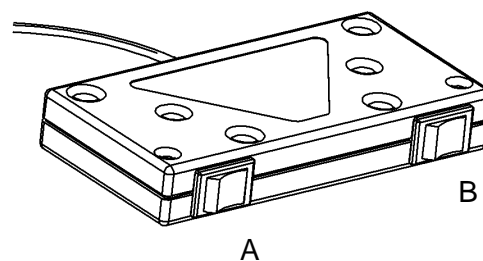

Performance

Performance, load/speed

Speed [mm/sec.]

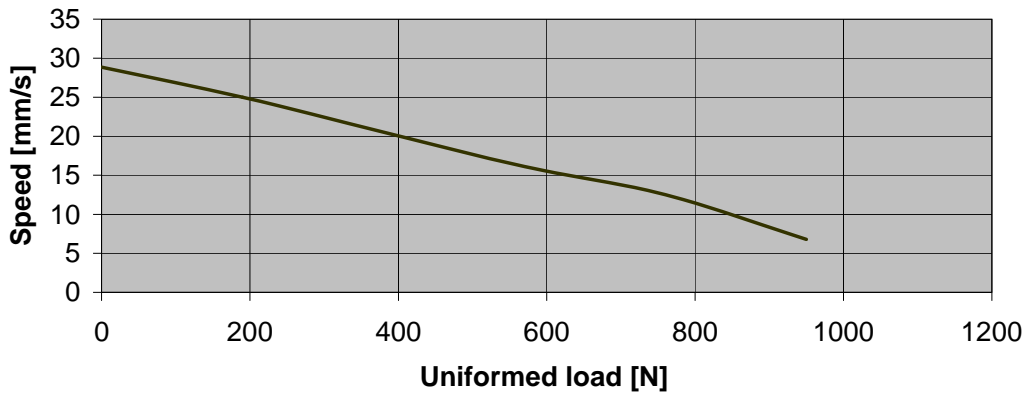

Rigidity in frame

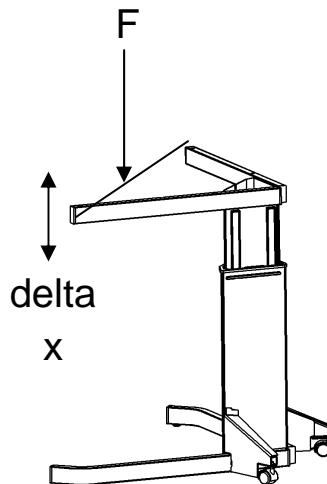

Deflection x [mm]

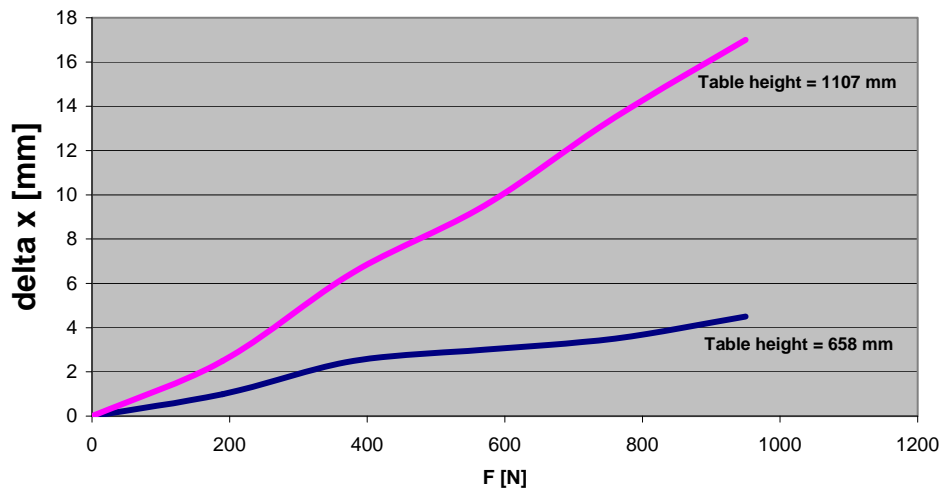

Safety and tests

All products have been tested up against the following norms:

ISO/DIS 8019

DS/ISO 7172

The norms mention above is possible to find at the website in the section “Norms and approvals”.

DECLARATION OF CONFORMITY

We hereby declare, under our sole responsibility that the following products:

- ConSet sit and stand tables product type 501-7

which are covered by this statement, are in conformity with the following standards and other normative documents::

- Counsel Directive 98/37/EF
- Counsel Directive 89/336/EØF with later changes
- Counsel Directive 73/23/EØF with later changes

With reference to the Machinery Directive (98/37/EF) please be aware:

- the sit and stand table is considered a machine and
- the sit and stand table may not be used until it has been assembled and installed according to the instructions.”.

Tabletop drillings

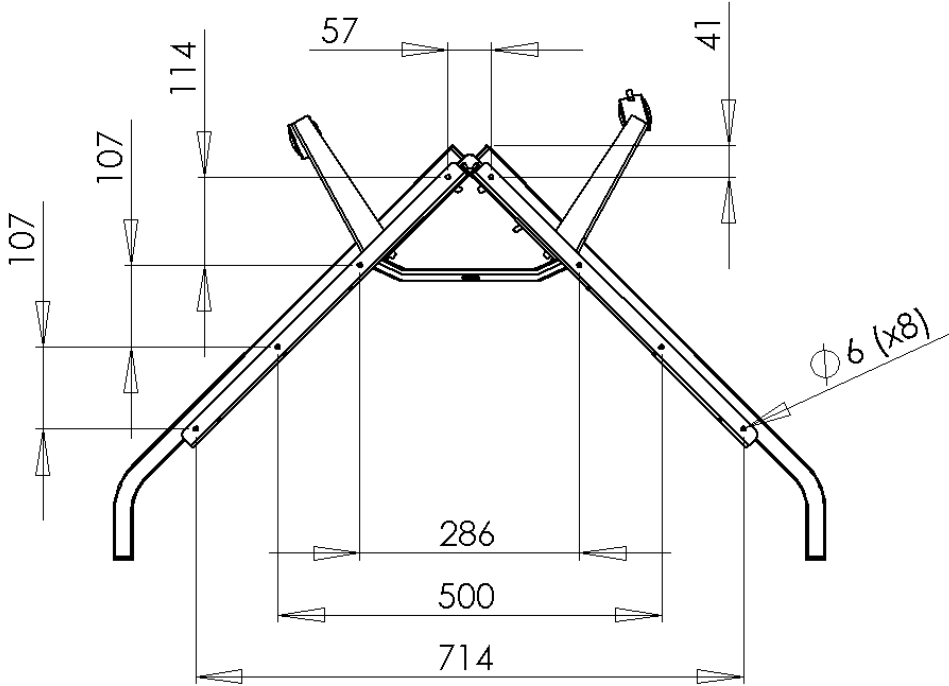

Component specifications

Metal sheet parts:	St 37-2
Gear parts:	St 70-2
Gear motor:	CSE 24V 300047
Power supply:	60 W AC Power Transformer Consumption: 60 Watts; Standby: Max 0,9 Watts
Plastic components:	PEHD, PA6
Surface treatment	Visible metal parts powder coated in black/"alu" colour Non visible metal parts are surface treated (e.g. zinc plated)