

# UPLIFT DESK®

## UPLIFT 2-Leg Height Adjustable Standing Desk

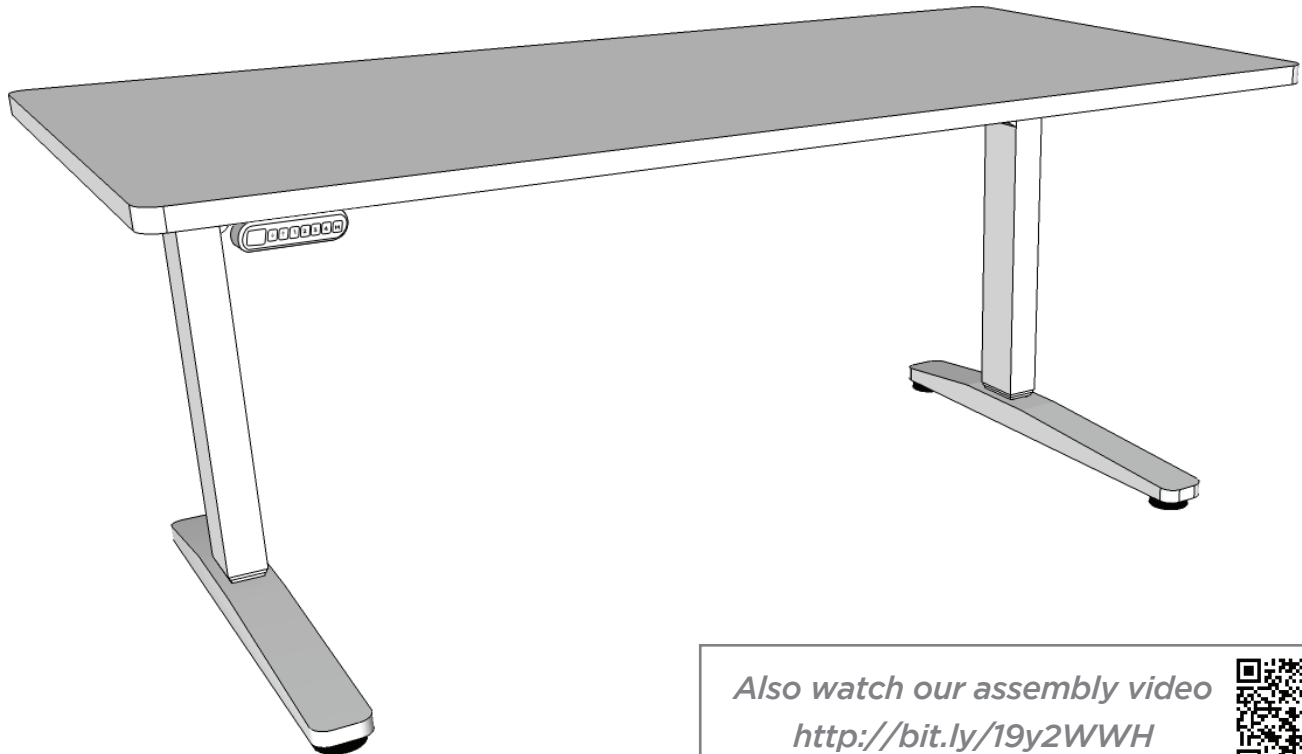

Also watch our assembly video  
<http://bit.ly/19y2WWH>



## DIRECTIONS FOR ASSEMBLY AND USE

TABLE OF CONTENTS		PAGE
1	Safety and Warnings	2
2	Usage	2
3	Parts List	3
4	Assembly Instructions	4
5	Desk Placement	7
6	Programming	7
7	Troubleshooting	8
8	Technical Specifications	9

### SAVE THESE INSTRUCTIONS:

Any user or installer of desk base must study this manual carefully. If this desk is sold, please provide the manual to the buyer, installers, or support personnel operating the product.

## 1. SAFETY AND WARNINGS

When using an electrical furnishing, basic precautions should always be followed, including the following: Read all instructions before using the desk.

**FAILURE TO COMPLY WITH OR OBSERVE ALL INSTRUCTIONS AND WARNINGS REGARDING THE USE OF THIS PRODUCT MAY RESULT IN SERIOUS PROPERTY DAMAGE OR BODILY INJURY.**

**DANGER** - To reduce the risk of electric shock, Always unplug this furnishing from the electrical outlet before cleaning, or before putting on or taking off parts.

**WARNING** - To reduce the risk of burns, fire, electric shock, or injury to persons:

- Close supervision is necessary when this furnishing is used by, or near children, invalids, or disabled persons. Keep children away from electric height-adjustable desks, control units, and keypads. There is a risk of injury and electric shock.
- Use this table only for its intended use as described in these instructions. Do not use attachments not recommended by the manufacturer.
- Keep the table close to the power socket/outlet to be easily accessible.
- Never operate this table if it has a damaged cord or plug, if it is not working properly, if it has been dropped or damaged, or dropped into water.
- Keep the cords away from heated surfaces.
- Do not open any of the components: legs, control box, or keypad. There is a danger of electric shock. Do not insert anything into any seam or opening.
- Keep all electrical components away from liquids.
- Do not operate where aerosol (spray) products are being used or where oxygen is being administered.
- Do not use outdoors.
- Inappropriate use of this product may cause property or bodily injury.
- Check surroundings on all sides before using the desk. Body parts and property can be crushed if trapped between an immobile obstacle and the desk's range of motion.
- Ensure the length of power cords are accounted for when operating the desk. Monitors, computers, speakers, anything with a cord that is not long enough for the desk's range of motion could be pulled down or have its wires broken. Items pulled off the desk may cause other items to fall.
- Please provide this manual to any users, installers, or support personnel operating the product.



MAKE SURE NO OBSTACLES ARE IN THE DESK'S PATH AND ALL CORDS ARE OF APPROPRIATE LENGTH FOR DESK TRAVEL. FAILURE TO COMPLY WITH OR OBSERVE ALL ASSEMBLY, SAFETY, AND OPERATION INSTRUCTIONS AND WARNINGS REGARDING THE USE OF THIS PRODUCT MAY RESULT IN SERIOUS PROPERTY DAMAGE OR BODILY INJURY.

## 2. USAGE

This height adjustable desk has an electric motor and is designed for use in dry work areas only. The desk height is adjustable so that it can be positioned at the most ergonomically suitable height. These desks are designed only for the purposes included in this manual. They should not be used in environments with high humidity or dampness. Any other use is at user's risk.

Do not move around, crawl, or lie under the desk frame. Do not sit or stand on the desk frame.

Children should never use the desk unless they are supervised by adults.

**Liability:** Under no circumstances does the manufacturer accept warranty claims or liability claims for damages caused from improper use or handling of the desk frame other than that which is described in this operation manual.

### 3. PARTS LIST

#### Tools required

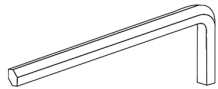

Allen wrench (included)

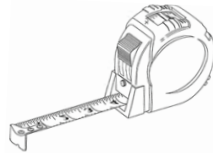

Tape Measure

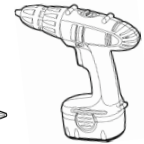

Phillips Head Screwdriver and/or Power Drill

#### Components

**1** Leg  
(qty 2)

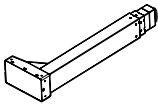

**2** Foot  
(qty 2)

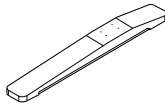

**3** Crossbar end  
(qty 2)

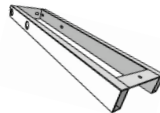

**4** Crossbar rail  
(qty 2)

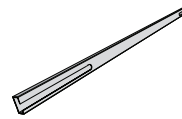

**5** Side bracket  
(qty 2)

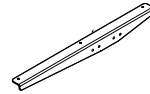

**6** Adhesive pads  
(qty 10)

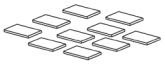

**7** Control box  
(qty 1)



**8** Keypad  
one of two types  
(qty 1)



**9** Leveling stud  
pre-installed  
(qty 4)



**10** Cables  
(qty 1 power cable and  
2 connecting cables)

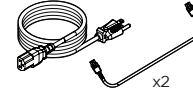

**11** Cable clip  
(qty 10)



**12** M6x14 Machine screw  
(qty 24)



**13** M6x10 Machine screw  
(qty 8)



**14-a** #10x5/8 Wood screw  
(qty 12)



**14-b** #10x1/2 Machine screw  
(qty 8)



Please count all pieces before disposing of any carton or packing material. Use a padded or carpeted area for assembly to avoid damage. For ease and safety, we recommend two people for assembly.

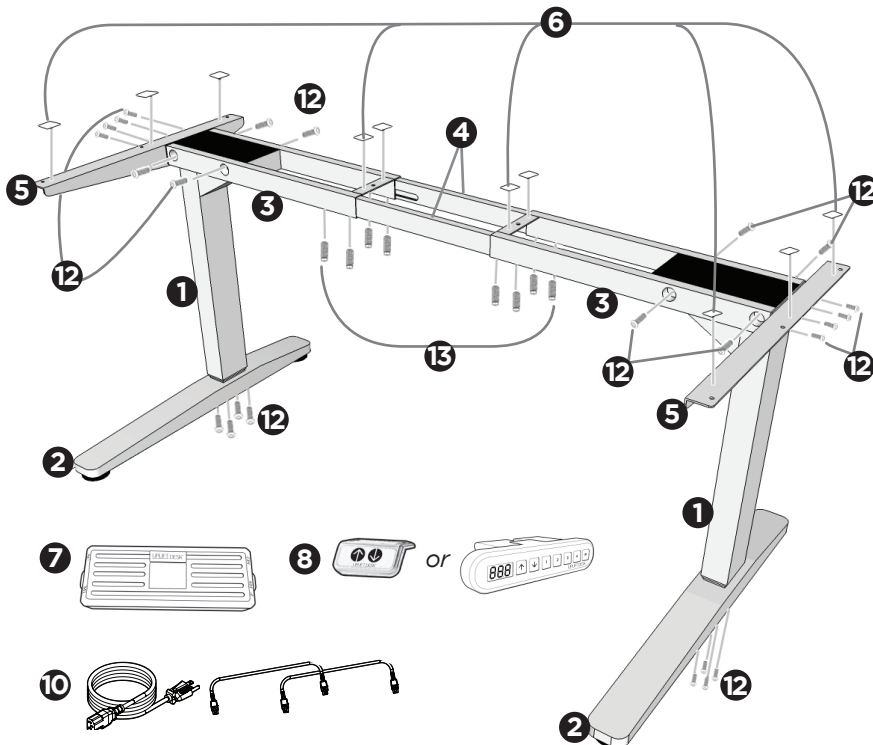

part	Description	Qty
<b>1</b>	Leg	2
<b>2</b>	Foot	2
<b>3</b>	Crossbar end	2
<b>4</b>	Crossbar rail	2
<b>5</b>	Side bracket	2
<b>6</b>	Adhesive pads	10
<b>7</b>	Control box	1
<b>8</b>	Keypad	1
<b>9</b>	Leveling studs (pre-installed in feet)	4
<b>10</b>	Cables (Power & two connector wires)	3
<b>11</b>	Cable clips (not pictured)	10
<b>12</b>	M6x14 Machine screw	24
<b>13</b>	M6x10 Machine screw	8
<b>14-a</b>	#10x5/8 Wood screw (not pictured)	12
<b>14-b</b>	#10x1/2 Machine screw (not pictured)	8

## 4. ASSEMBLY INSTRUCTIONS

- A. Fully separate the Crossbar ends (part 3) you will find the Crossbar rails (parts 4) inside.

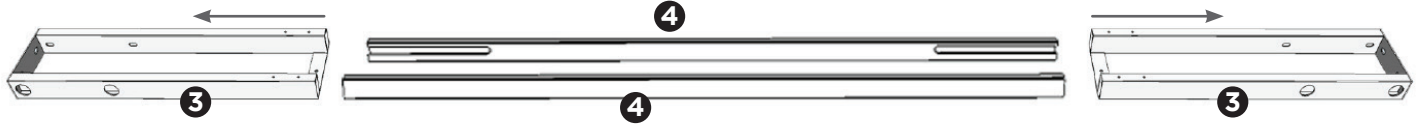

- B. Position the Crossbar ends (part 3) on their sides. You will be inserting the Legs (part 1) into the Crossbar ends from below. When positioned correctly, the mount tabs will be facing up (fig. 1).

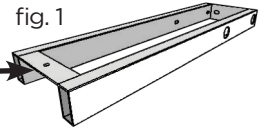

Now, place the Legs (part 1) into the Crossbar ends from the bottom (fig. 2). Using the supplied Allen wrench, insert four (4) M6x14 Machine screws (part 12) into the Crossbar ends, and **rotate each screw only a few turns**. Do not tighten fully until step D.

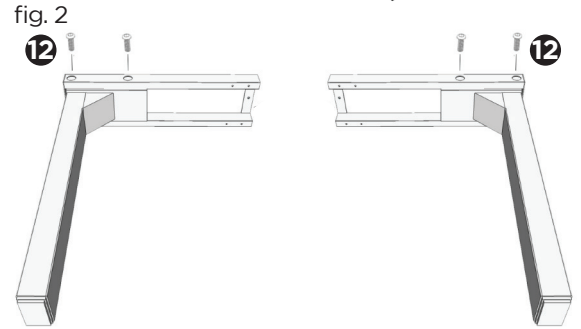

If you drop a screw inside the Crossbar end, simply tilt to retrieve the screw.

- C. Take the two Side brackets (part 5) and attach them to the Leg assemblies, using four (4) M6x14 Machine screws (part 12) each. Use the Allen wrench, and **rotate each screw only a few turns**. Do not tighten fully until step D.

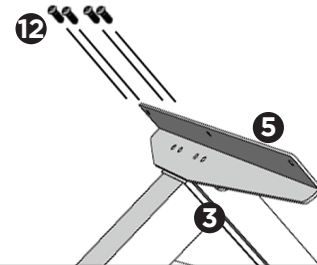

If you are having trouble getting all the screws started, it is because other screws are too tight. You'll need to back out some screws in order to loosen the tolerance of the screw holes.

- D. Once all of the parts are connected, you can now tighten the eight (8) Screws from Step B and the eight (8) Screws from Step C (16 screws in total).

- E. Remove backing from the Adhesive pads (part 6) and position along the assembly as shown. Be sure to not cover any of the holes.

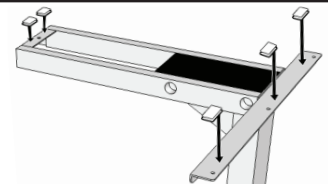

- F. Slide Crossbar rails (part 4) back into Crossbar ends (part 3). Ensure the slots of the Crossbar rails are facing inward. The slot on the Crossbar rail is offset; it will need to be aligned in a specific way to allow for the already installed Machine screws. Make sure that the Crossbar rail (part 4) can slide all the way to the end of the Crossbar end (part 3). If it doesn't fit, take the Crossbar rail out and flip it over, with the slots facing inward and near the top of the edge, further from the floor.

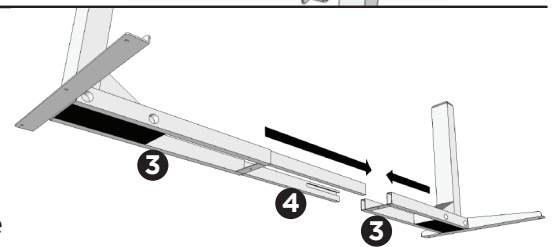

**Note:** Do not use the Crossbar rails if your desktop is less than 43" wide. A Crossbar rail will make your frame too wide to fit onto these desktops.

Set aside the Crossbar rails and space the halves of the frame accordingly on the underside of the desktop.

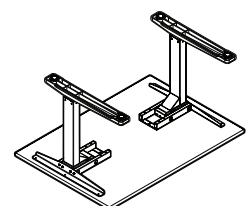

**G.** Attach each Foot (part 2) with four (4) M6x14 Machine screws (part 12) and tighten bolts in a cross pattern.

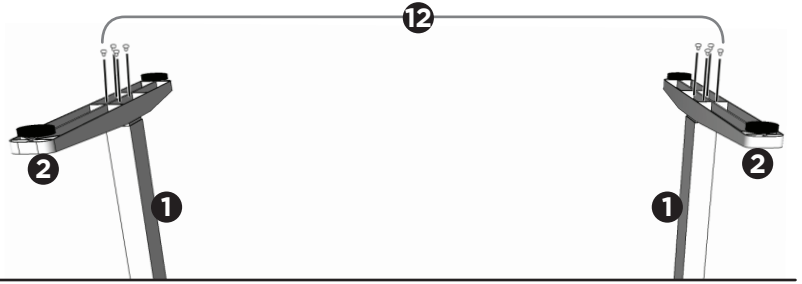

**H.** Your desktop may or may not be pre-drilled. Please check both sides of the desktop before placing the desk base on it for pre-drilling! Carefully place the frame upside down on the underside of the desktop.

**Note: minimum top size: 43" wide x 24" deep**

Adjust the width of the base to fit the desktop by sliding the two halves outward (42.125" to 74.75" max).

If your desktop is not pre-drilled, place the base where you want it. Some will want the frame to be all the way to the edge of the desk. We recommend leaving at least 1/2" of desktop width on either side of the Side brackets.

The desk feet are deeper than the Side brackets. If your top is 25.5"-27.5" deep and you want the rear edge of the top in line with the rear edges of the feet, offset your desktop toward the back.



**I.** Secure the Center rails at both ends using eight (8) M6x10 Machine screws (part 13), four (4) per side. Maximum width is 70".

Ensure that the Machine screw hits the metal center rail by sliding the center rail as needed.

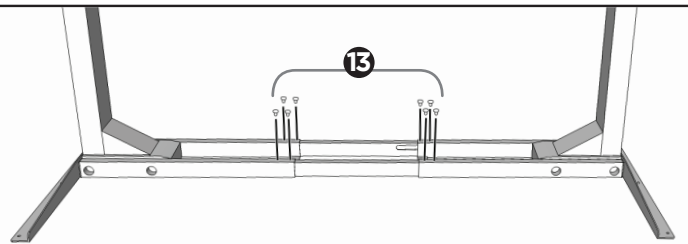

**J. Choose the screw to fasten your frame to your desktop.**

If your desktop does not have metal threaded inserts, use the #10x5/8 Wood screws (part 14-a)



If your desktop does have metal threaded inserts use the #10x1/2 Machine screws (part 14-b)



Double-check that the desk frame is properly positioned on the underside of the desktop.

Attach the desk frame assembly to the underside of the desktop using eight (8) of the screws that you have chosen.

3 per Side bracket  
1 per Crossbar end

6 total  
2 total

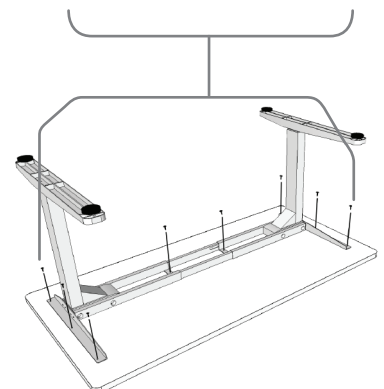

**K.** Using the wires, connect the Legs (part 1) to the Control box (part 7) and the Keypad (part 8) Wires as per the diagram below.

Do this so you can place the Keypad and Control Box under your desk in such a way so that the cables can reach.

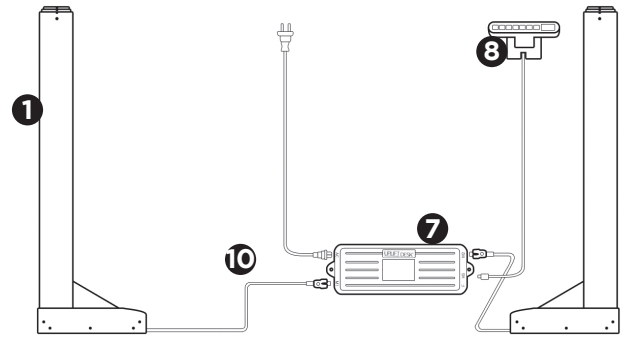

**L.** Use two (2) of the #10x5/8 Wood screws (part 14-a) to attach the Control box (part 7). Ensure enough clearance at the wire ports for cable connections. Use the pre-drilled hole locations, or place where preferred.

**Note:** Do not over-tighten the screws, it may break the plastic

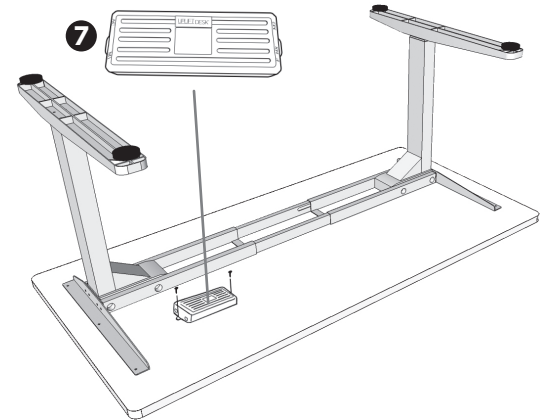

**M.** Place the Keypad (part 8) so the front of the Keypad runs flush with the desktop edge (or recessed up to 1/8"). The Keypad can be placed anywhere along the front edge of the desk, but we recommend placing it near the side so it doesn't interfere with your chair or legs when seated. Use the pre-drilled hole locations, or place where preferred.

Use two (2) of the #10x5/8 Wood Screws (part 14-a) to attach the Keypad (part 8) to the desktop. Use the adhesive-backed Cable clips (part 11) to secure all wires so they don't sag.

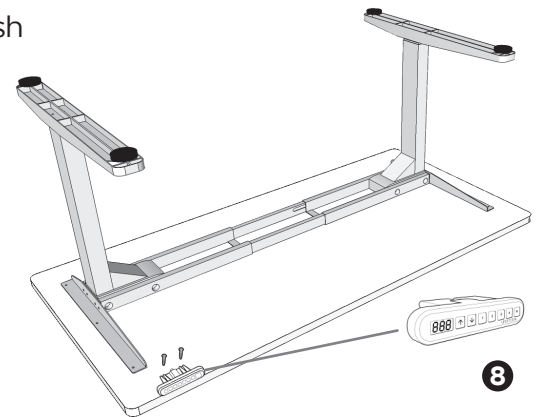

**N.** Turn the assembled desk right-side up. With two people, grab the desk by the frame and desktop equally, and turn the desk right-side up. Adjust the Leveling studs (part 9) on the Feet (part 2) as needed.



**NOTE: Make sure no obstacles are in the desk's path.  
Make sure cords are a length that will accommodate the change in height.**

**O.** Plug the power cord into a 120v outlet.

**IMPORTANT!**

**You must RESET the desk prior to use!**

Press and hold the DOWN button on the Keypad until the desk reaches its lowest height. Release the DOWN button. Press and hold the DOWN button again until the LED display reads "RST" or about 10 seconds on non-LED handset models. Release the DOWN button. Press and hold the DOWN button again until the desk lowers a little bit more, slightly rises and stops. Release the DOWN button. Your desk is now ready to use.

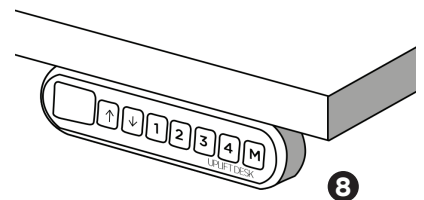

To program up to four presets:

Use the up/down buttons to find a desired height, then press "M" followed by a number 1 - 4.

## 5. DESK PLACEMENT

Following desk assembly, adjust the Leveling studs or casters (sold separately) on the feet so that the desk is level and does not shift its position.

When moving the desk, if casters are not installed, use a two-person lift and lift the desk so that it can be moved without dragging. Dragging the desk may cause the frame and screws to pull loose from the desktop.

When moving the desk, DO NOT lift the desk by the desktop alone, or the frame, alone. Support both the frame and the desktop equally. Favoring one over the other can stress the fasteners connecting the desk frame to the desktop. Lower the desk completely and lift the desk by grasping the frame.

Choose a placement for the desk that's a safe distance from window frames, radiators, furniture, etc., so that people do not get stuck or trapped by the desk.

Check cord clearance, so that they don't get jammed. Then connect the desk to the 120v outlet and the desk is ready for use.

Do not place any objects underneath the desk that are taller than 20".

## 6. PROGRAMMING:



### SETTING THE LED RETRACTED HEIGHT

If you've purchased an UPLIFT Desk and the Advanced 1-touch digital keypad, press the DOWN button on the Keypad until the frame reaches its lowest position. Measure the height of the frame from the floor to the underside of the desktop and if the number on the LED display does NOT match your measurement, follow these steps: 3

Press and hold the DOWN button again until the LED display reads "RST" 4 

Press and hold the "M" button (about 5 seconds) until the LED displays the flashing starting height. (If the display returns to "RST" before the next step is taken, repeat this step.)

#### To change the value of the starting height:

By 0.1s:  
Increase: press the UP button   
Decrease: press the DOWN button 

By 1.0s:  
Increase: press the "1" button 1  
Decrease: press the "2" button 2

By 10.0s:  
Increase: press the "3" button  
Decrease: press the "4" button

Once the new value is displayed, wait about 5 seconds and the display will return to "RST". Finish the reset process by pressing and holding the DOWN button again until the desk lowers a little bit more, slightly rises and stops. Release the DOWN button. The new starting height value is saved and your desk is now ready to use.

Note: the LED display has a  $\pm 0.1$  tolerance.

## 6. PROGRAMMING (continued):

### SETTING THE UPPER & LOWER LIMITS (Advanced 1-touch digital keypad only)

This frame is designed to go to its minimum and maximum heights, allowing for the widest possible range. If you prefer to change the settings to a more narrow range, follow these steps:

Make sure the power is ON and a number reads in the LED display (if no number appears, please follow the Reset procedure described in the TROUBLESHOOTING section below).

#### To Set the Upper-Limit Position:

Use the UP/DOWN buttons to move the frame to the desired maximum height position. Make sure the UP button was the last button you pushed. Press and hold the “M” button until the LED display flashes “S -” once and let go of the button. Then press and release the button 2 more times in quick succession. The LED display will change to “999” on the third push, and then automatically return to the selected height. The new upper limit is now set.

S-  
999

#### To Set the Lower-Limit Position:

Use the UP/DOWN buttons to move the frame to the desired minimum height position. Make sure the DOWN button was the last button you pushed. Press and hold the “M” button until the LED display flashes “S -” once and let go of the button. Then press and release the button 2 more times in quick succession. The LED display will change to “000” on the third push, and then automatically return to the selected height. The new lower limit is now set.

S-  
000

#### To Remove the Upper/Lower Limit Positions:

Use the UP or DOWN button to move the desk to any new position. Press and hold the “M” button until the LED display flashes “S -” once and let go of the button. Then press and release the button in succession until the display changes to “555” (ignore any interim readings). After a few seconds, the display will automatically change back to the numbered height position. The upper and lower limits are now removed.

S-  
555



A RESET procedure requires the desk frame to fully retract (beyond any lower limit set). Please ensure that you have the proper clearance below the desk frame.



After the upper and lower limits are set, the previous memory positions (1, 2, 3, 4) may be outside the new range of movement. If so, simply reset the memory positions.

If you attempt to revise a previously set upper or lower limit and it is outside of the existing range, you will need to remove the previously set upper/lower limits first.

## 7. TROUBLESHOOTING

### --Reset Instructions--

If experiencing error messages showing on the Keypad or no response when trying to raise or lower:

- Unplug the power cord and hold the DOWN button for 30 seconds.
- Plug the power cord back in.
- Press and hold the DOWN button on the Keypad until the desk reaches its lowest height. Release the DOWN button. Press and hold the DOWN button again until the LED display reads “RST” or about 10 seconds on non-LED keypad models. Release the DOWN button. Press and hold the DOWN button again until the desk lowers a little bit more, slightly rises and stops. Release the DOWN button. Your desk is now ready to use.
- The Keypad will then display the current height, and you should be able to operate it now.
- You may need to do this if the desktop is ever unplugged or loses power.

If the Keypad displays error messages “Er1” through “Er13”, confirm that all wired connections are secure (legs to cables, cables to control box). Then perform the reset procedure above. If the error message persists after the reset procedure or if the height between the legs exceeds 1.5” stop the reset procedure and contact The Human Solution (800.531.3746 or info@thehumansolution.com).

If the Keypad displays “Hot”, let the base cool down for 20 minutes.

If the desk seems to be uneven, try the reset instructions above. If that does not work you may need to adjust the levelers at the bottom of the foot.



## 8. TECHNICAL SPECIFICATIONS

<b>Height Range</b>	24.25" - 50.25" (without desktop)
<b>Base Width</b>	42.125" min - 74.75" max
<b>Travel Speed</b>	1.5" per second (varies, slowest w/ maximum load)
<b>Weight Capacity</b>	355 lbs
<b>Duty Cycle</b>	10%, Max. 2 mins on, 18 mins off
	4 Memory presets Soft Start/Stop Adjustable leveling studs

**i** In the event of a power outage or if the power cord is unplugged, a manual reset may be necessary. (see Reset Instructions above)

**i** This product is designed with a duty cycle of 10%. (2 min. on, 18 min. off)



**!** If casters are not installed, use a two-person lift and lift the desk so that it can be moved without dragging. Dragging the desk may cause the frame and screws to pull loose from the desktop.

**!** Keep children away from electric height-adjustable desks, control units, and handsets. There is a risk of injury and electric shock.

**!** Do not open any of the components: lifting columns, control box, or handset. There is a danger of electric shock.

**!** Keep all electrical components away from liquids.

© **Copyright Notice:** This guide is a component of the UPLIFT Desk™. This guide is a part of the scope of delivery, even if the item is resold. This guide is also available on the UPLIFT Desk website: [upliftdesk.com](http://upliftdesk.com). Excerpts or copies may not be forwarded to third parties or used in any other published form without the prior written consent of UPLIFT Desk.  
These instructions are subject to United States copyright law.