

UPLIFT DESK®

UPL021 Dual Monitor Arm Assembly Instructions

Step One

- Place monitors face down on a flat surface, making sure not to scratch monitor screen.
- Attach a monitor mount to the back of each monitor using a Phillips screwdriver and the M4 screws provided. There are two screw lengths provided for your convenience. Use the longest screw length that will fully tighten the monitor to the mount. The mount is designed to fit the industry standard VESA 75mm & 100mm hole patterns.

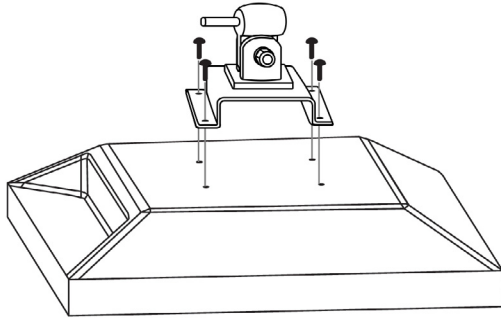

Step Two

- Check the mounting clamp to make sure it will fit the desk/table that you are mounting it to. It has been supplied to fit a desk/table top thickness up to 1 1/4". If a larger clamping range is required, remove the lower clamp and change positions to enable a larger clamping range (see pictures below for instructions on how to change the clamp range). Maintain the smallest clamping distance possible to ensure the best stability of the arm.
- Once the clamp gap has been set up, insert the clamping washer on top of the clamping screw and tighten to the desk/table in the desired location with the 1/4" hex key provided.

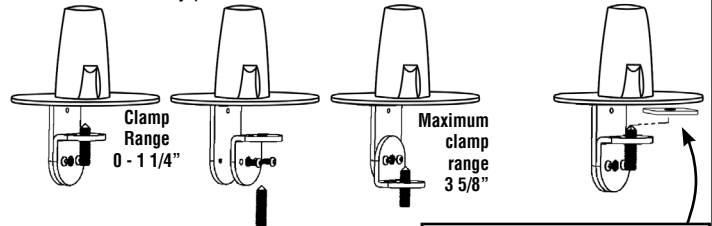

- Remove both 1/4" screws and the clamping screw
- Rotate lower clamp to achieve proper clamping gap and reinsert 1/4" screws and clamping screw.

Clamping Washer
To be used between the clamping bolt and the underside of the work surface

Step Three

- 1 Insert the dual arm adapter into the base riser.
- 2 Insert the gas assisted arms into the dual arm adapter.
- 3 Insert the extension arms into the gas assisted arms.
- 4 Insert monitor mounts (with monitors attached) into the extension arm.
- 5 Once the arms are assembled, you will need to tighten the small screws at each joint to prevent the arms from lifting apart or drifting. Use the 1/8" hex key provided. Make sure not to overtighten the screws.

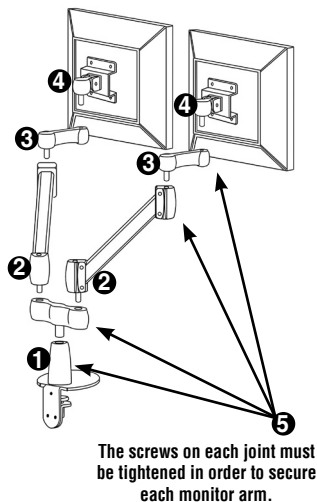

Step Four

- Insert the provided cable hangers into the underside of the extension arm and the gas assisted arm.
- Run the monitor cables through the hangers. Make sure the cables are not pulled tight. There should be some slack in the cables to allow the arm to freely move without being restricted by the cables.

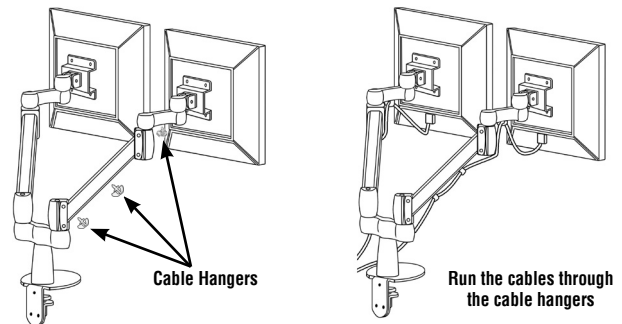

Step Five

- The gas cylinder is factory set for a standard 17" monitor. If you find that after you place the monitor into the proper position that it either lifts or drops, then the tension of the gas cylinder needs to be adjusted.

- To adjust the tension on the gas assisted arm, use the supplied 5/32" hex key and turn in the appropriate direction to increase or decrease tension as necessary (see picture to the right). Adjust the tension of the gas cylinder until the monitor holds its position when you let it go. Note, the monitor must be attached to the monitor mount in order to counterbalance correctly.

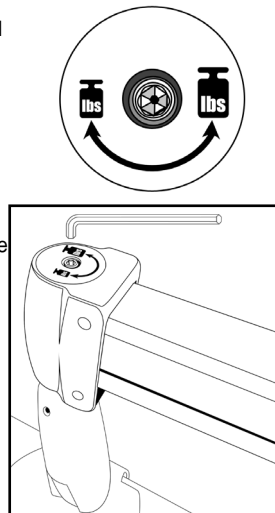

Guidelines for Proper Monitor Placement

Screen Distance: Set to approximately 18"-28" from user. To reduce eye strain, place monitor about an arm's length from eyes. If print is too hard to read, it is better to make the print larger on your screen than to move the screen closer.

Monitor Height: The top of the monitor should be level with your eyes.

Monitor Tilt: The monitor should slightly up so it's easier to see the screen when the top of the monitor is level with your eyes.

