

eurotech ASSEMBLY INSTRUCTION

Remove all items from the carton . Verify all pieces before assembly.

PART LIST

KEY	QTY	DESCRIPTION	KEY	QTY	DESCRIPTION
1	2	Sled Base	5	2	Steel Bar
2	1	Seat Cushion	6	2	Backrest Screw (Short)
3	1	Seat Plastic Cover	7	4	Seat Screw (Longer) + Washer
4	1	Plastic Backrest	8	4	Caster

STEP 1.

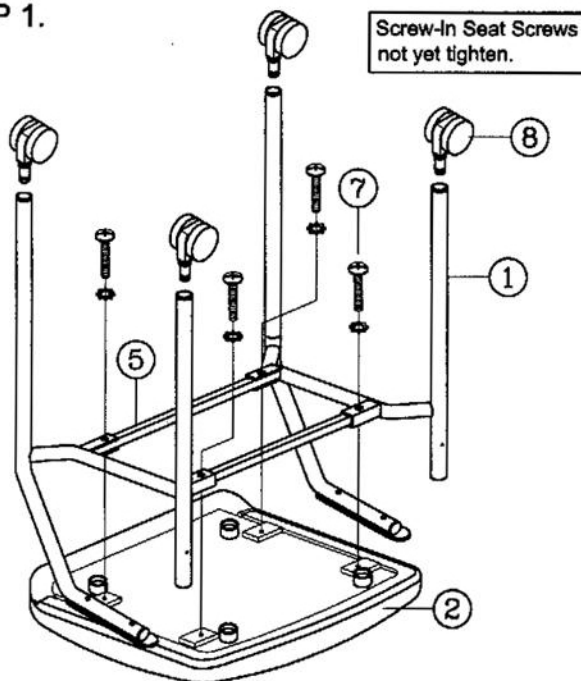

STEP 2.

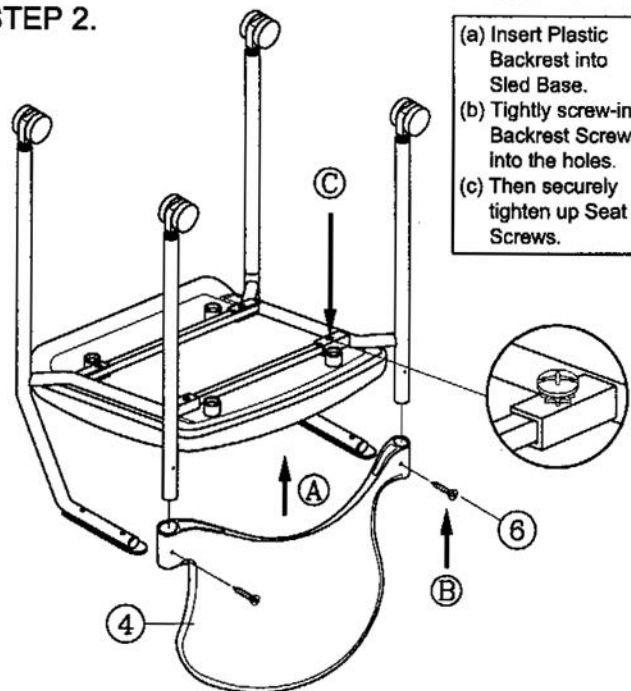

STEP 3.

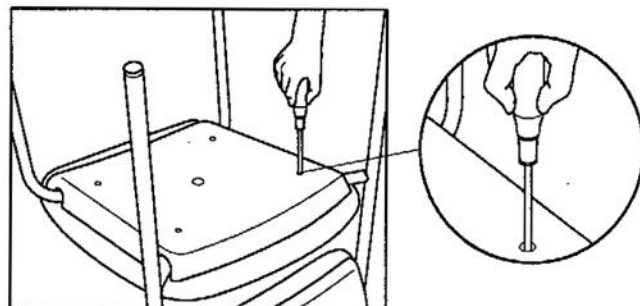
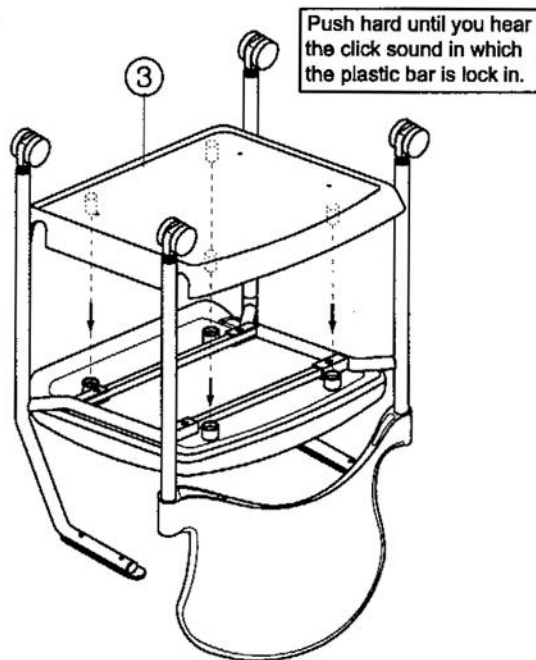

PREVENTIVE MAINTENANCE AND WARNING !

- From time to time, check to make sure screws are securely tightened. Holes on PP shell are for convenient checking.

PREVENTIVE MAINTENANCE AND WARNING!

- USE THIS PRODUCT ONLY FOR SEATING ONE PERSON AT A TIME.
- DO NOT USE THIS CHAIR AS A STEP STOOL / LADDER.
- DO NOT USE CHAIR UNLESS ALL BOLTS , SCREWS AND KNOBS ARE TIGHT . AT LEAST EVERY SIX MONTHS , CHECK ALL BOLTS , SCREWS AND KNOBS TO BE SURE THEY ARE TIGHT.
- IF ANY PARTS ARE MISSING , BROKEN , DAMAGED OR WORN , STOP USE OF THE PRODUCT UNTIL REPAIRS ARE MADE USING FACTORY AUTHORIZED PARTS.
- FAILURE TO FOLLOW THESE WARNINGS COULD RESULT IN SERIOUS INJURY.

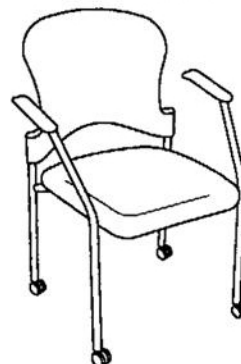

FS8270