

ASSEMBLY INSTRUCTION

REMOVE ALL ITEMS FROM THE CARTON. VERIFY ALL PIECES BEFORE ASSEMBLY.

PARTS LIST

KEY	QTY	DESCRIPTION	KEY	QTY	DESCRIPTION	KEY	QTY	DESCRIPTION
1	5	CASTER	8	2	ARMREST	11	1	SEAT
2	1	BASE	7	1	BACKREST	12	2	M8x10mm BACKREST SCREW
3	1	SEAT POST	8	1	M10x25mm BACKREST BOLT +	13	1	M5 SIZE ALLEN WRENCH
4	1	SEAT POST COVER			WASHER	14	2	ARM WIDTH ADJUSTMENT KNOB
5	1	MECHANISM +	9	1	M6 SIZE ALLEN WRENCH			+ WASHERS
		SLIDERS (PRE-ASSEMBLED)	10	1	BACKREST POST			

STEP 1.

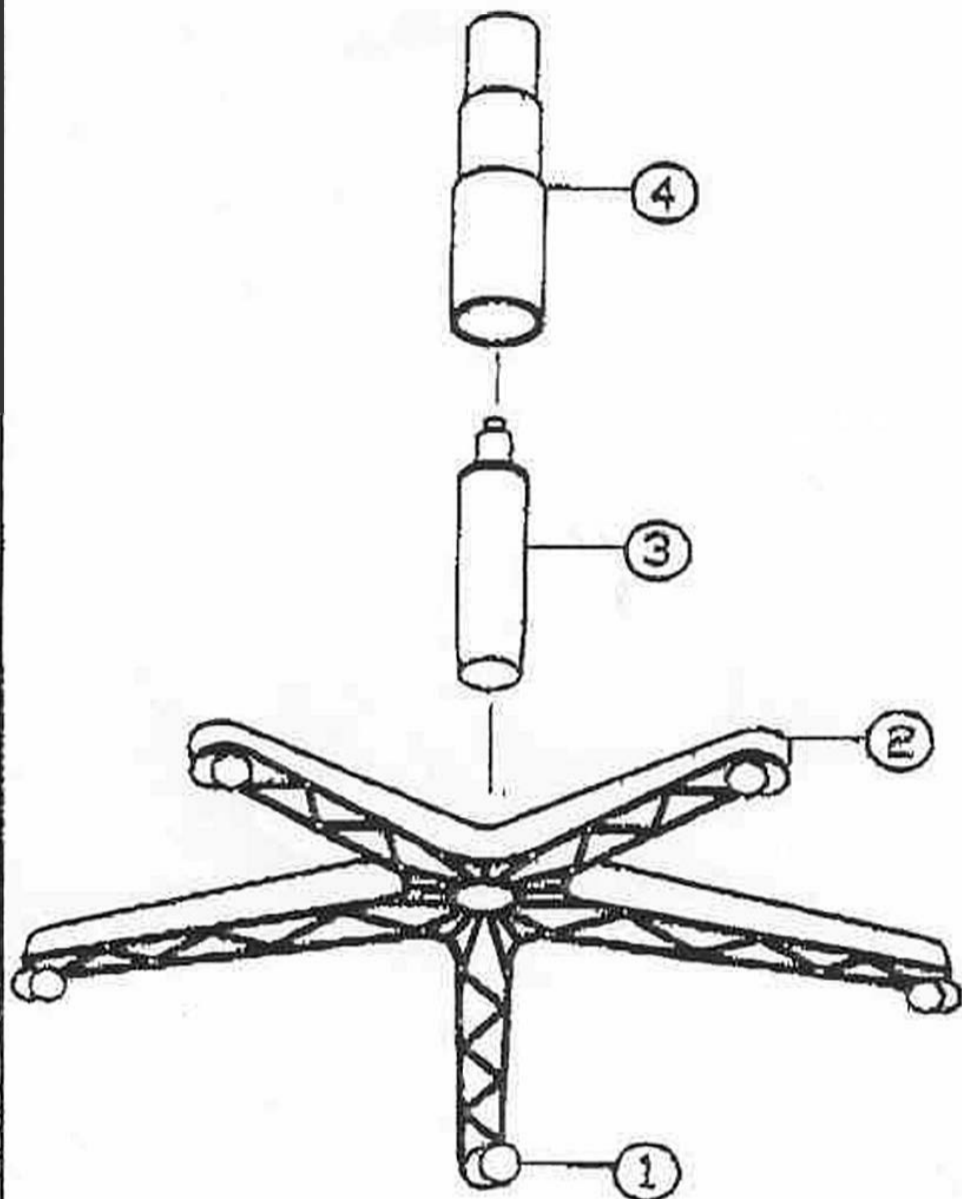

STEP 2.

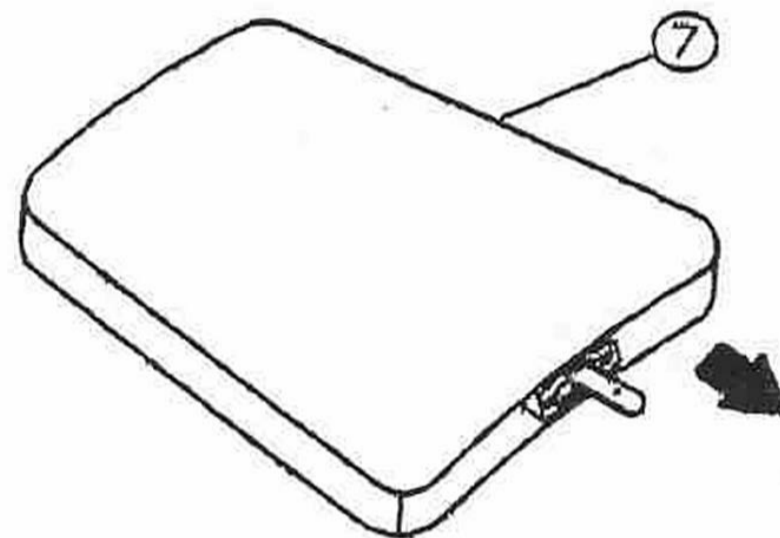

STEP 3.

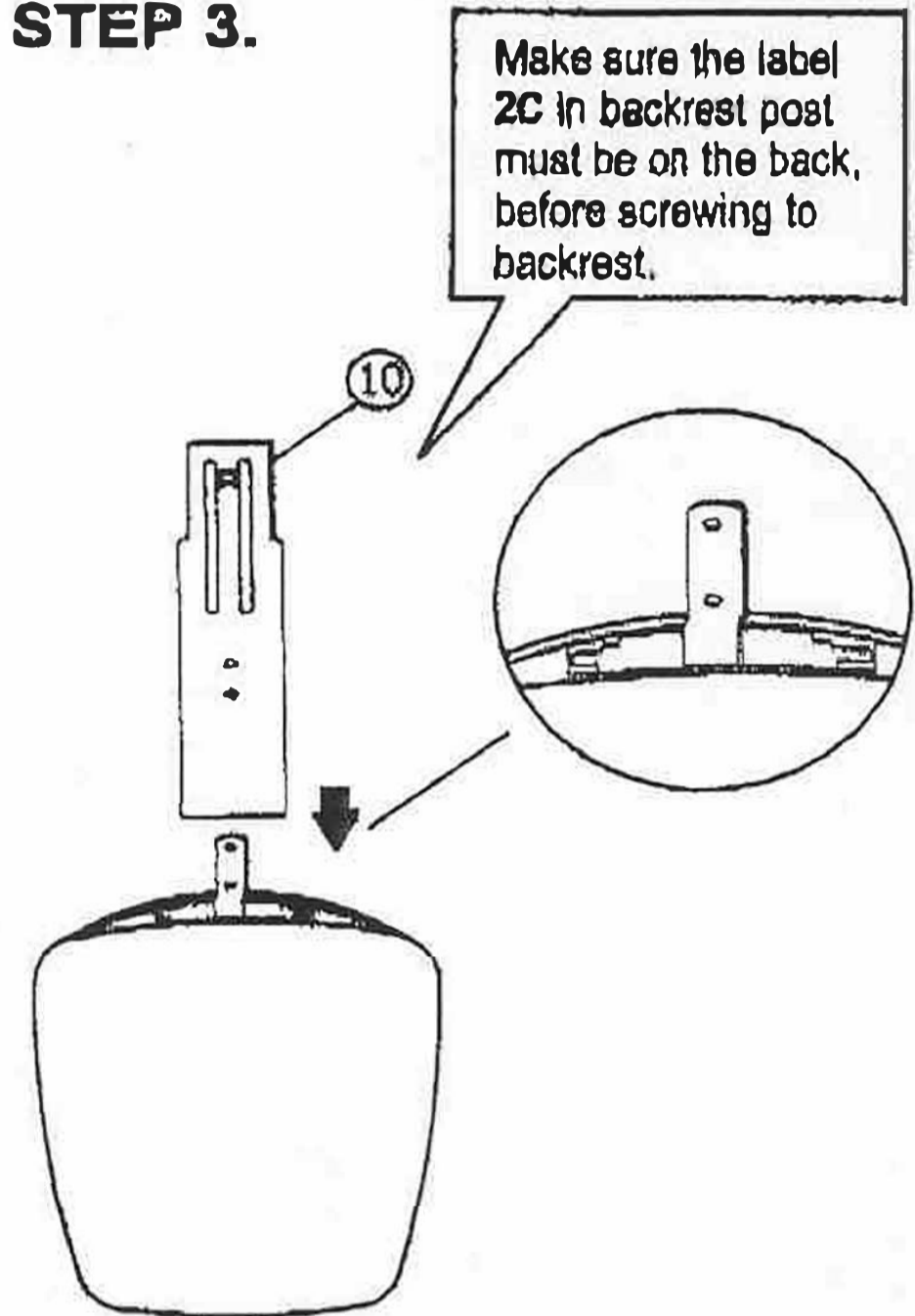

STEP 4.

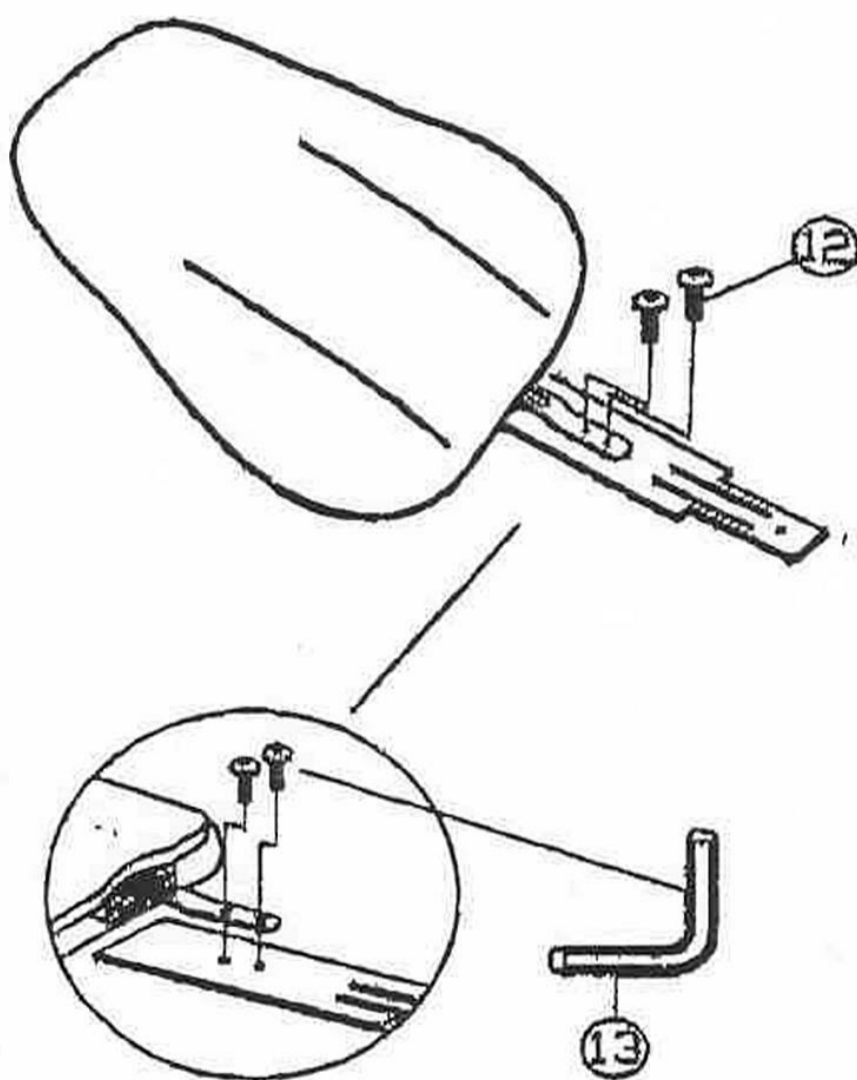

STEP 5.

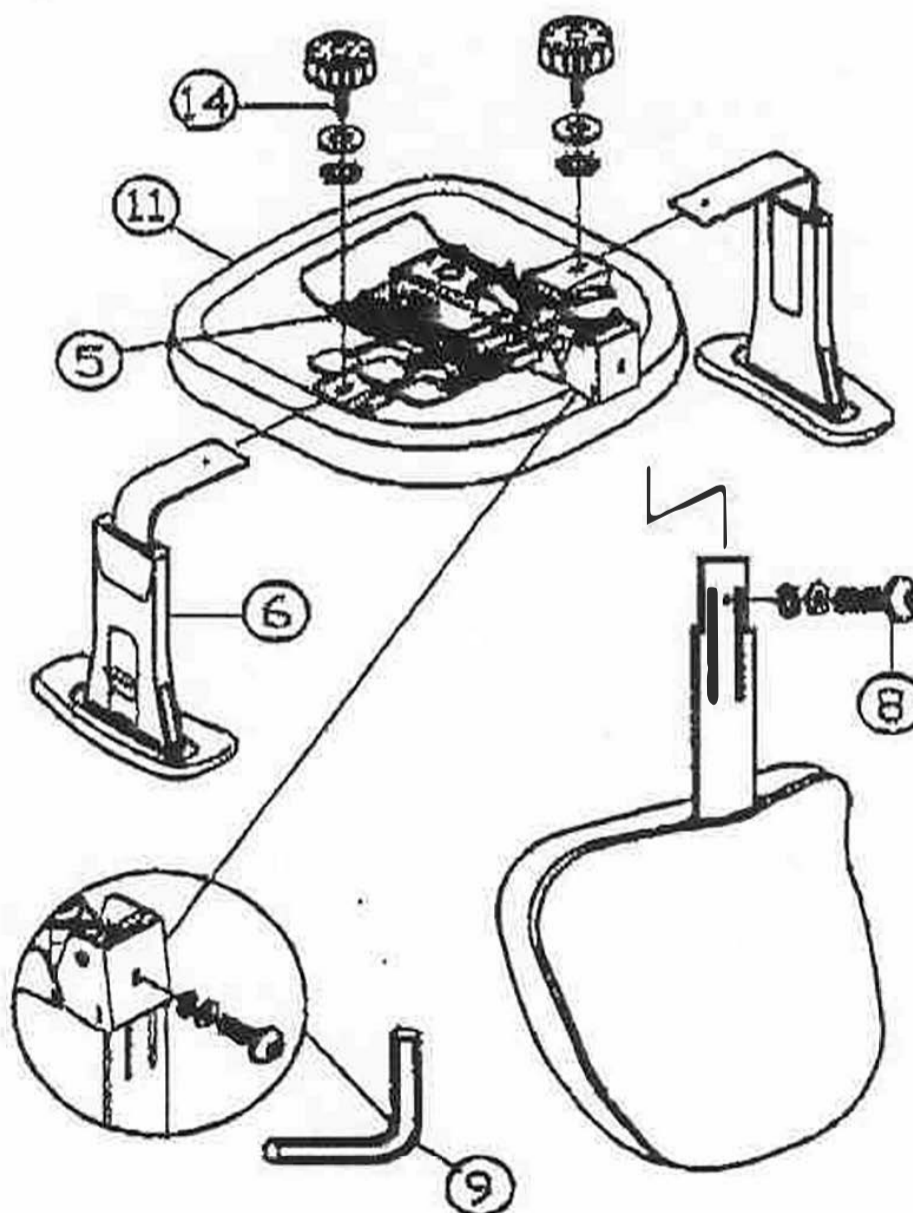

STEP 6.



PREVENTIVE MAINTENANCE AND WARNING

- USE THIS PRODUCT ONLY FOR SEATING ONE PERSON AT A TIME.
- DO NOT USE CHAIR AS STEP STOOLLADDER.
- DO NOT USE CHAIR UNLESS ALL BOLTS, SCREWS AND KNOBS ARE TIGHT. AT LEAST EVERY SIX MONTHS, CHECK ALL BOLTS, SCREWS AND KNOBS TO BE SURE THEY ARE TIGHT.
- IF ANY PARTS ARE MISSING, BROKEN, DAMAGED OR WORN, STOP USE OF THE PRODUCT UNTIL REPAIRS ARE MADE USING FACTORY AUTHORIZED PARTS.
- FAILURE TO FOLLOW THESE WARNINGS CAN RESULT TO SERIOUS INJURY.

available at:

 **humansolution®**

800.531.3746

info@thehumansolution.com

thehumansolution.com