

UPLIFT DESK[®] Spacer for Keyboard Tray

ACC030

Package Contents:

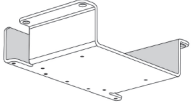

Small spacer
(qty 1)

5/16" Machine screws
(qty 8)

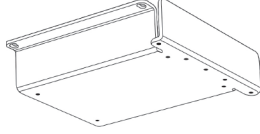

Large spacer
(qty 1)

1/2" Machine screws
(qty 2)

Use the items that come with your Keyboard Tray:

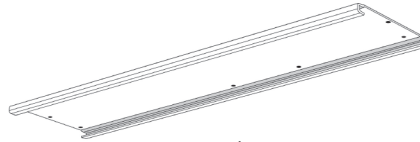

Track



Track guard

5/8" Wood screws
(qty 8) Back bumper

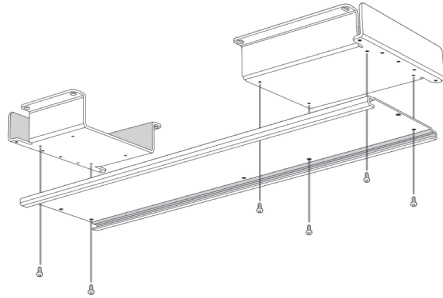

Step 1

Using six (6) 5/16" Machine screws, attach the Track to the Small and Large spacers as shown.

Note: There are two lengths of screws: 5/16" are the shorter ones, and 1/2" are longer. Do not use interchangeably.

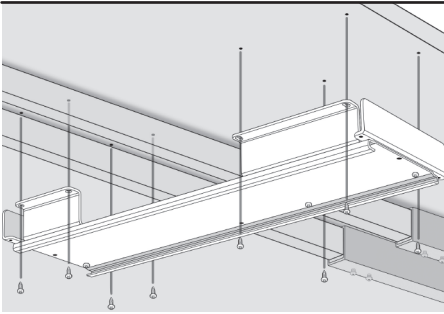

Step 2

Place the assembly over the center rails crossbar ends. Mark screw locations. (If pre-drilling, use 1/8" diameter drill bit and drill 1/2" deep) Then attach to desktop using eight (8) 5/8" Wood screws.

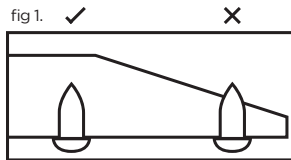

Note-

When pre-drilling on a desktop with a center-cut ergo edge, take care to ensure that the screw is not too close to the ergo edge to avoid piercing the desktop with the screw. (see fig. 1)

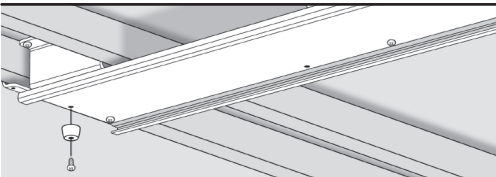

Step 3

Attach the Back bumper to the rear side of the assembly. Use one (1) 1/2" Machine screw in the center hole.

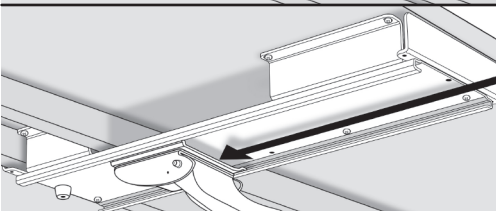

Step 4

Slide the Keyboard tray mechanism onto the Track.

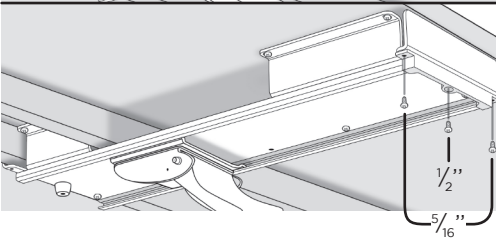

Step 5

Attach the Track guard to prevent the Keyboard tray from sliding off. Use two (2) 5/16" Machine screws on the right and left holes, and one (1) 1/2" Machine screw in the center hole.

Copyright Notice: These instructions are a component of the UPLIFT Spacer. These instructions are part of the scope of delivery, even if the item is resold. These instructions are also available on the UPLIFT Desk website: upliftdesk.com. Excerpts or copies may not be forwarded to third parties or used in any other published form without the prior written consent of UPLIFT Desk.
These instructions are subject to United States copyright law.