

General Assembly Instructions

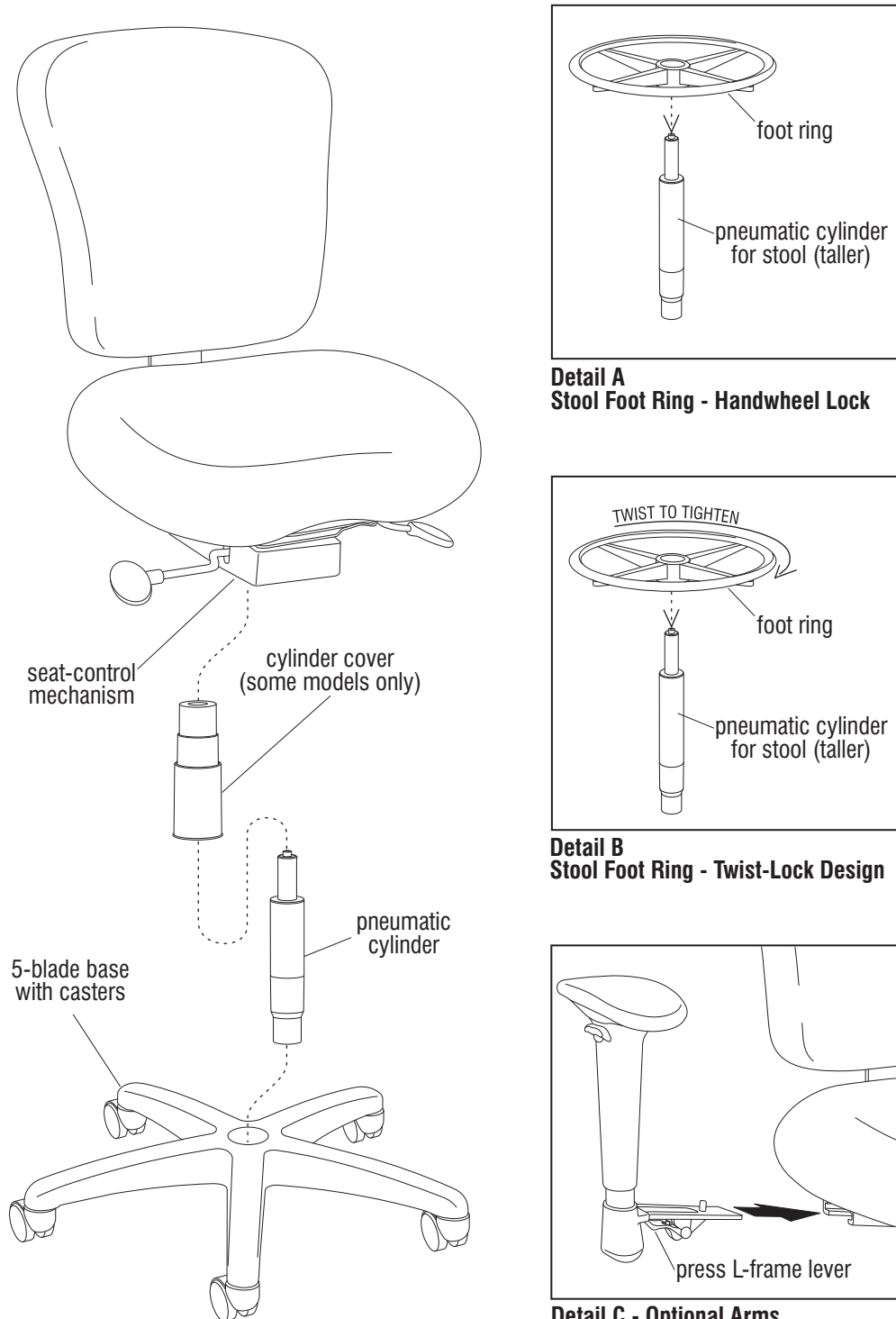
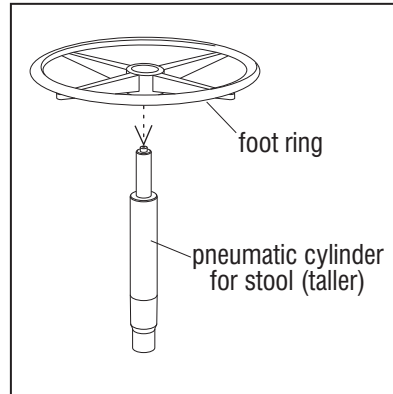
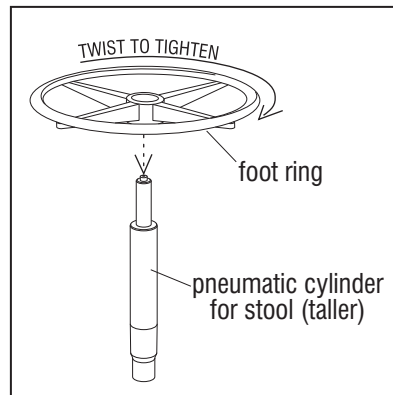

Figure 1



Detail A
Stool Foot Ring - Handwheel Lock



Detail B
Stool Foot Ring - Twist-Lock Design

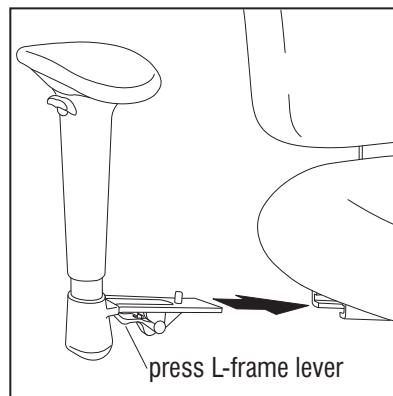

Detail C - Optional Arms
Jr39, Kr200 Series, Kr300 Series
& Kr500 Series

1. Carefully unpack all contents from packaging, then locate and identify the parts shown in Figure 1.

2. Turn the 5-blade base with casters to the upright position onto the floor. Orient the pneumatic cylinder as shown placing the larger end of the cylinder into the hole in the center of the base as illustrated (Figure 1).

Note: If assembling a stool, position foot ring as illustrated and slide it down onto the thicker body of the pneumatic cylinder. Tighten handwheel on foot ring to secure (Detail A). If foot ring is a no-handwheel design, twist the foot ring clockwise to secure in place (Detail B).

3. Carefully position the seat assembly over the pneumatic cylinder, aligning the hole in the underside of the seat-control mechanism with the top, smaller end of the pneumatic cylinder. Press the seat assembly onto the pneumatic cylinder, then sit on the seat to completely drive the components together. While sitting, actuate the right-hand height-adjust lever to move seat to its lowest height position, then press lever and release seat pressure to adjust up to comfortable sitting height. Failure to do so could result in personal injury (Figure 1).

4. If chair was ordered with arms, they are installed to each side of the chair by first positioning the arm as illustrated. While depressing the lever under the arm's L-frame support, drive the lower L-frame into the receiver at the underside of the seat until arm can be locked in position (Detail C).