

# Acoustic Phone Booth

SKU: ACU011

## Specifications

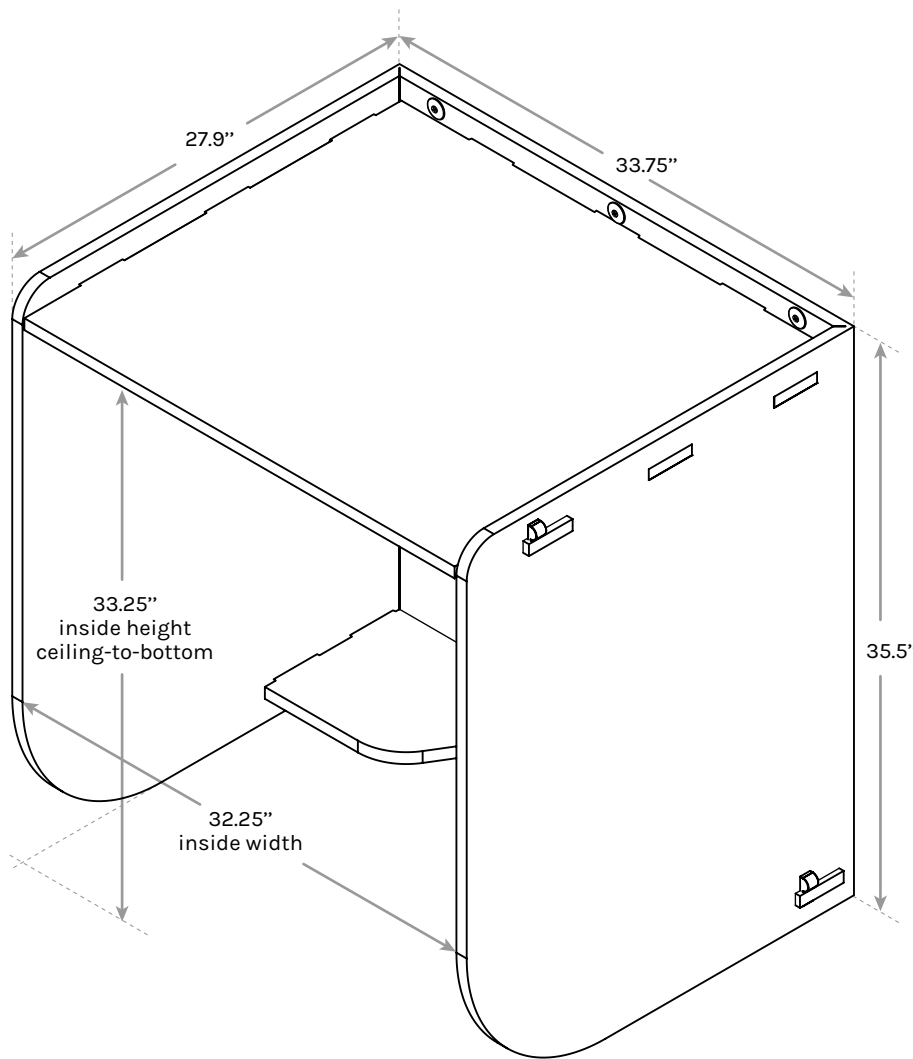

### TOP VIEW

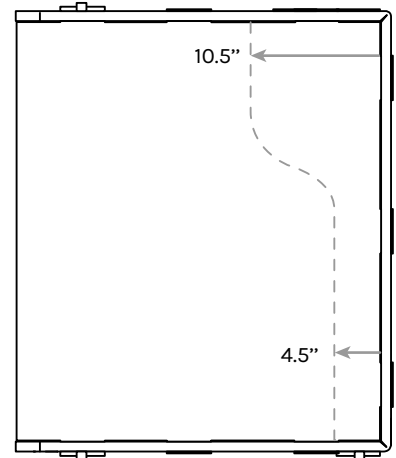

### SIDE VIEW

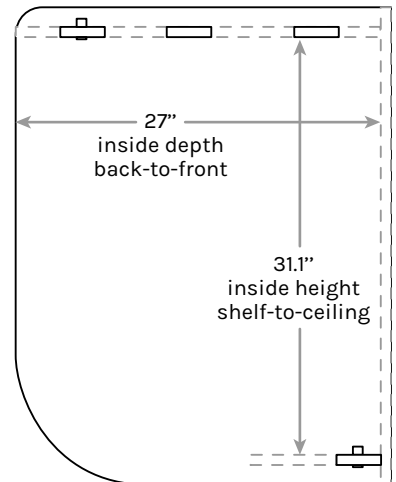

<b>Panel Material</b>	Polyester Acoustic Fiberboard 50% recycled water bottles!
<b>Panel Thickness</b>	.75"
<b>Fire Rating</b>	Euro Class B
<b>Noise Reduction Coefficient</b>	>.86
<b>Panel Colors</b>	Gray (outside) & Green (inside); Charcoal (outside) & Gray (inside)
<b>Warranty</b>	15 year



For help with assembly, find our assembly instructions at <http://bit.ly/2MFeNBJ>

 For technical questions and support call 800-349-3839, email [info@upliftdesk.com](mailto:info@upliftdesk.com), or visit our chat service at [upliftdesk.com](http://upliftdesk.com)