

Keyboard Tray System with Quick Adjust Mech

UPLIFT DESK

SKU: KBT009

Package Contents

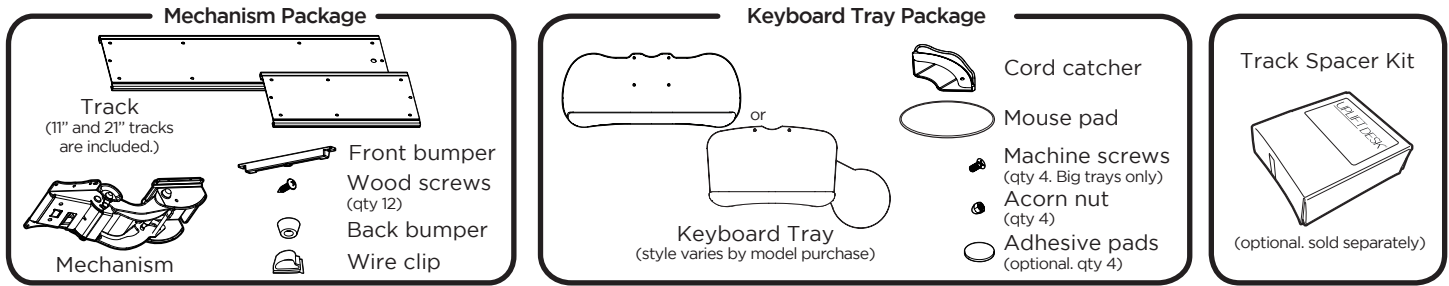

A Note Before You Begin:

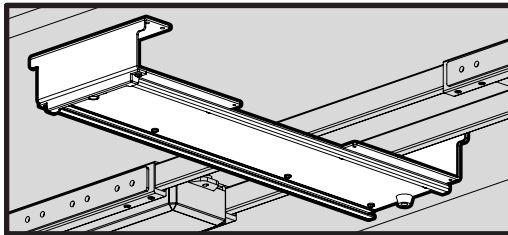

Before you begin the installation process, determine which of the included track lengths you will be using, 11" or 21". If you decide to use the 21" track and need to mount it over the desk frame crossbars, you will need to use the Track Spacer Kit (sold separately). Instructions for how to use the Track Spacer Kit are included in its packaging.

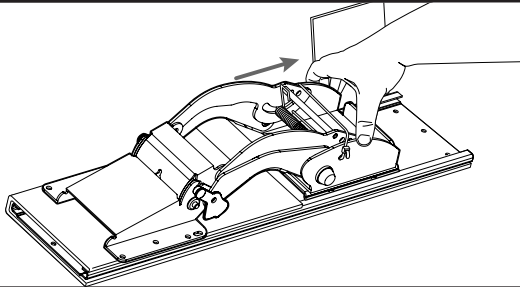

Step 1

The Mechanism will come shipped already slid into a Track. Unwrap the plastic and unfold the cardboard flap at the back, then hold the Mechanism by the base as shown, and slide it off the track.

A shipping pin or strap will keep the Mechanism from activating during this process.

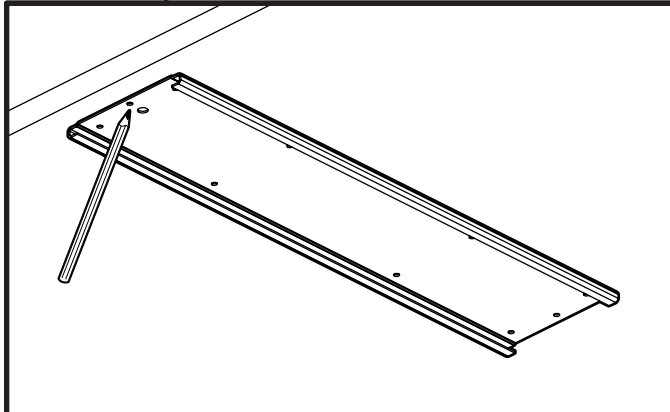

Step 2

If you are not using the Track Spacer Kit, place the Track underneath your desktop in the desired location, with about 1/2" from the front edge of the desktop to the front edge of the Track.* Using the Track as a template, mark the center of the holes with a pencil (ten holes on a 21" Track and eight holes on an 11" Track).

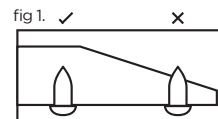

***Caution:** If you are attaching the Track to a desktop with a curved front edge, make certain there is 1-1/2" from the front edge of the desktop to the front edge of the Track. This will prevent the screws from piercing through the top of the desktop. (see fig. 1)

To make this step a little easier, if you own a drill, you can make pilot holes. Use a 1/8" diameter drill bit and, ensuring that you DRILL NO DEEPER THAN 1/2", drill pilot holes where you've made your marks on your desktop.

Note: Some UPLIFT desks are built with metal support bars embedded in the bottom side. They are clearly visible when looking under the desk. Be mindful of where your Track will be going, and be careful not to drill or screw into these support bars. The Track can be installed directly over a support bar; please refer to the note in Step 3 to show you how to do this.

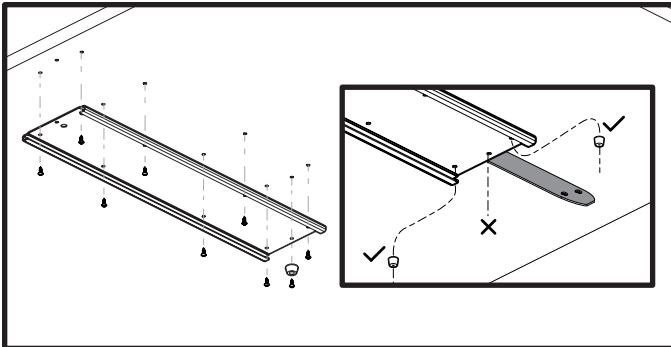

Step 3

Using eight Wood screws for the 21" track or six Wood screws for the 11" track, attach the Track to the underside of the desktop. Use one more screw to attach the Rear bumper, as shown.

Note: If you are mounting your Track on a desktop with a center support bar and you are not using a Track Spacer Kit, you can attach the Back bumper through either of the outside holes, as shown, to avoid hitting the bar. You can also shift your Track slightly to the left or right.

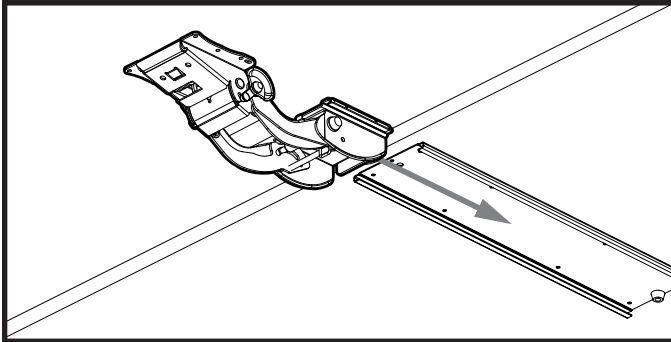

Step 4

Line up the Mechanism with the grooves on the Track, and slide it into place.

Leave the front portion of the Mechanism extended past the front edge of the desktop so that you can attach your Tray.

Please note: the Mechanism will not adjust up or down until the Tray has been attached and the shipping pin or strap has been removed (see step 6).

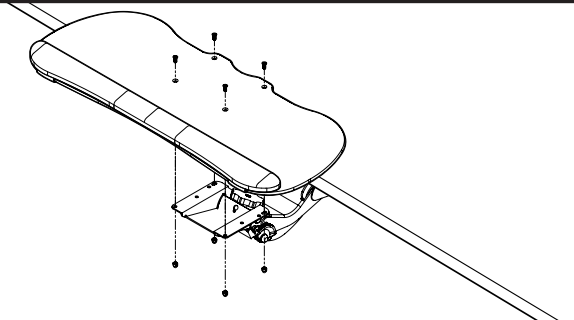

Step 5

For the Big Ultra-Thin and Big Standard Trays: Attach the Tray to the Mechanism by lining up the holes in the Tray with the holes on the Mechanism, and secure by inserting the four Machine screws through the holes in the top of the Tray, and attaching the four Acorn nuts onto them from below.

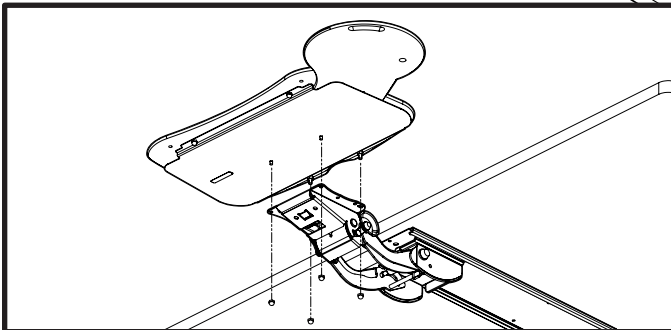

For the Switch Tray: Attach the Tray to the Mechanism by lining up the integrated screws on the bottom of the Tray with the holes on the Mechanism; secure in place by attaching the four Acorn nuts onto the screws from below.

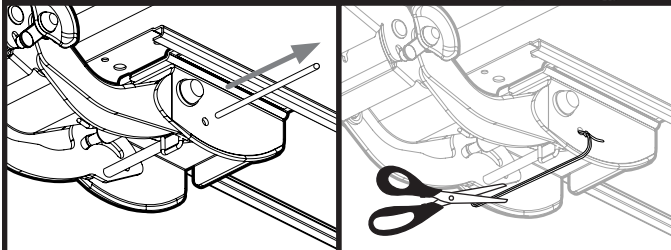

Step 6

The Mechanism ships with either a metal pin or plastic tie installed, which keeps it secure during shipment. To remove the pin, lift up on the front of the Tray while pushing the back of the Tray down in a twisting motion to allow the pin to be pulled out. To remove the plastic tie, just cut it and remove.

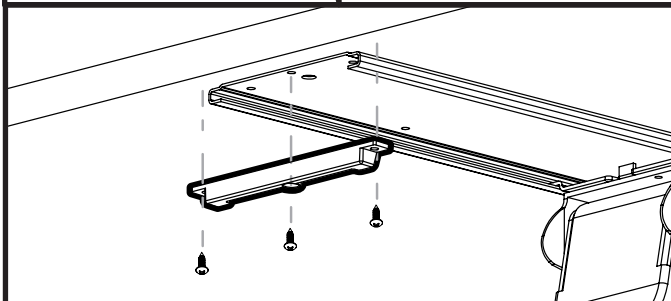

Step 7

Finally, lower the Tray and slide the assembly back on the Track. To adjust the height of the Tray, push down on the back of the tray while lifting the front in the same manner as used to remove the shipping pin. Install the Front bumper using three Wood screws.

Note: You may want to drill two pilot holes for the ends of the Front bumper using the directions from Step 2.

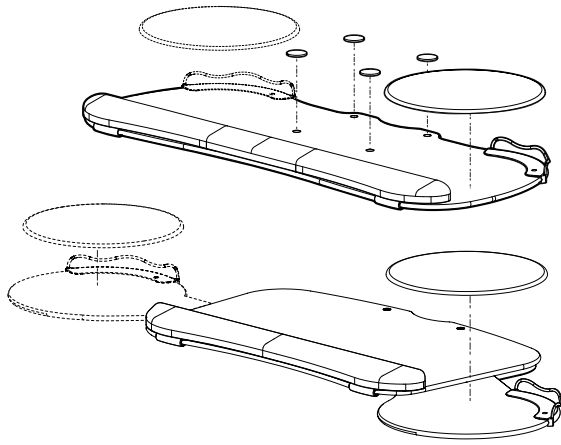

Step 8

For the Big Ultra-Thin and Big Standard Trays: Place the Mouse pad and Cord catcher on the desired side. The non-slip Adhesive pads keep keyboards from sliding can be placed over the heads of the machine screws, or in any other spot on the tray. Use the Wire clip anywhere you need to secure loose wires to prevent snags.

For the Switch Tray: Slide the mouse platform to desired side and place the Mouse pad and Cord catcher onto the platform. The non-slip pads can be placed in any position on the tray. Use the Wire clip anywhere to secure loose wires to prevent snags.

Adjustments applicable to all Keyboard Trays

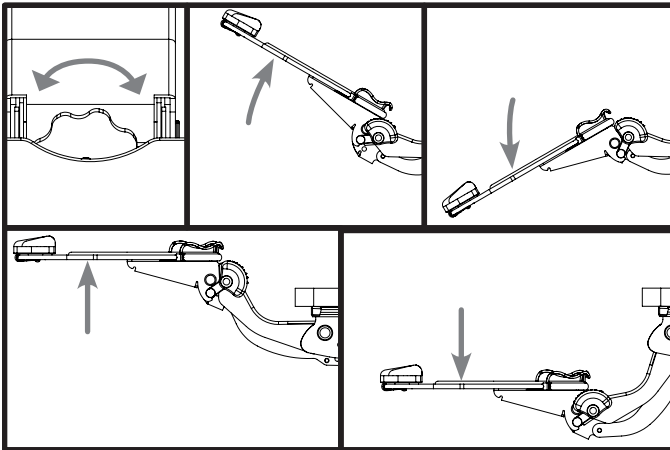

Tilt

To adjust the tilt of the Tray, turn the knob at the center of the tray. This will allow you to tilt the Tray up and down.

Height

To adjust the height of the Tray, push down on the back of the Tray while lifting the front in a twisting motion. Then raise or lower to the desired height.

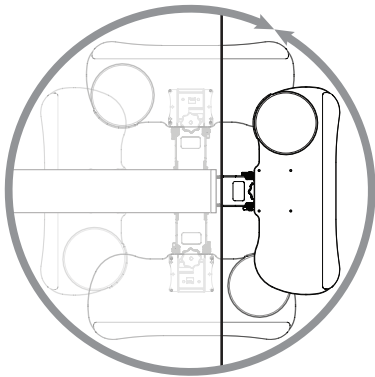

Rotate

The Tray rotates at the point where the Mechanism attaches to the Track. The Tray can rotate a full 360 degrees (unless it is obstructed by something underneath the desktop).

Adjustment applicable to the Switch Keyboard Tray only

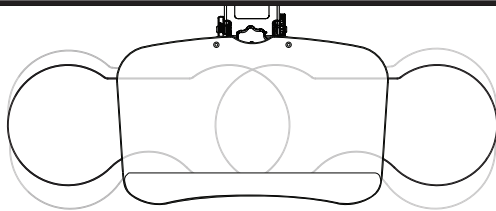

Swapping sides for your mousing platform

The mousing platform on the Switch tray can slide from the right or left side. It can also be adjusted forward and backwards.

⚠ CAUTIONS & WARNINGS

⚠ **CAUTION:** Read all instructions before assembly. Failure to assemble or operate properly may result in damage or personal injury. Retain manual for future reference.

⚠ **CAUTION:** Maximum weight limit for all keyboard trays is 10 lb. Do not overload.

© UPLIFT Desk • 800-349-3839 • info@upliftdesk.com • upliftdesk.com

UPLIFT DESK[®]

Work Better. Live Healthier

512-614-3152

800-349-3839

info@upliftdesk.com

upliftdesk.com

SAVE THESE INSTRUCTIONS

Study this manual carefully. If this product is sold, please provide this manual to the buyer, installers, or support personnel operating the product.



Copyright Notice: This guide is a component of this UPLIFT Desk accessory. This guide is a part of the scope of delivery, even if the item is resold. This guide is also available on the UPLIFT Desk website: upliftdesk.com. Excerpts or copies may not be forwarded to third parties or used in any other published form without the prior written consent of UPLIFT Desk. These instructions are subject to United States copyright law.