

# Kids Active Stool - 15"

SKU: CHR461

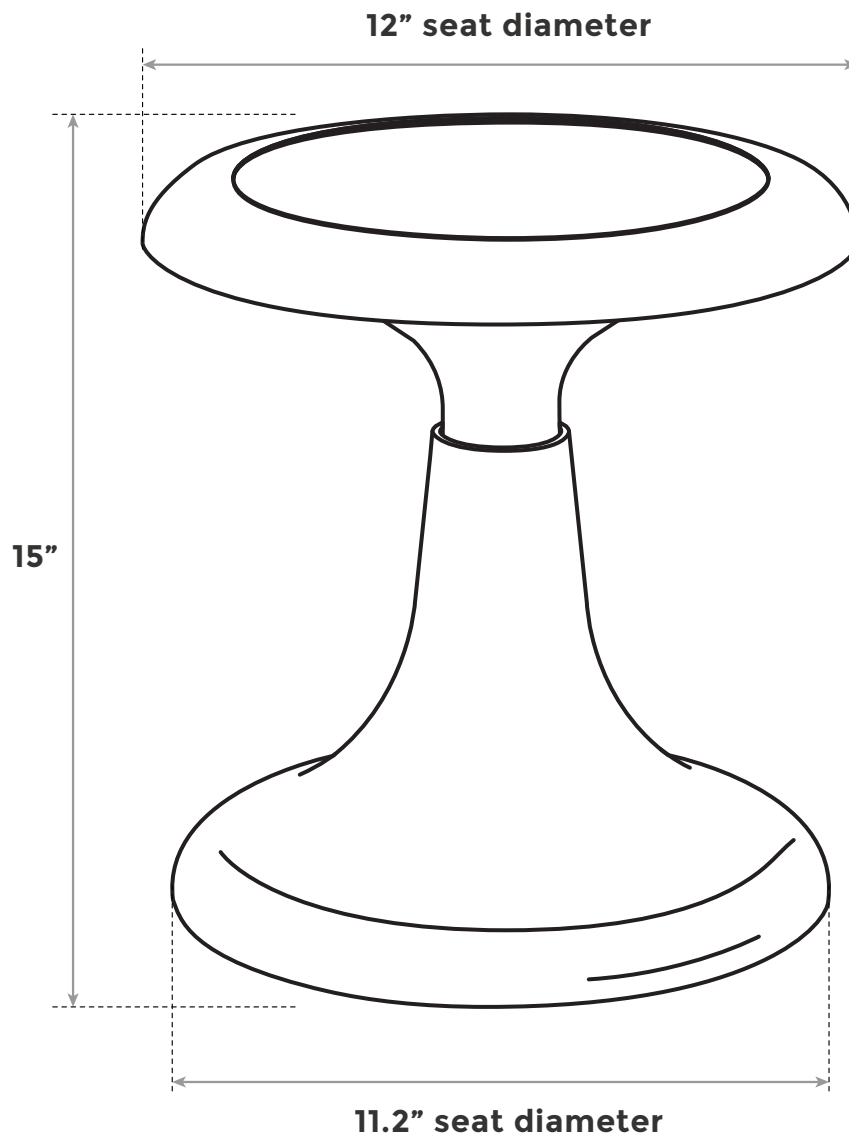

<b>Max weight load</b>	250 lbs.
<b>Stool material</b>	Plastic
<b>Seat material</b>	Rubber
<b>Dimensions</b>	15" H x 12" W
<b>Warranty</b>	1-year limited



For help with assembly, find our assembly instructions at <http://bit.ly/314Mj6N>



For a more in-depth look at this product, see our product video at <http://bit.ly/332zmfH>

 For technical questions and support call 800-349-3839, email [info@upliftdesk.com](mailto:info@upliftdesk.com), or visit our chat service at [upliftdesk.com](http://upliftdesk.com)

# Kids Active Stool - 17"

SKU: CHR462

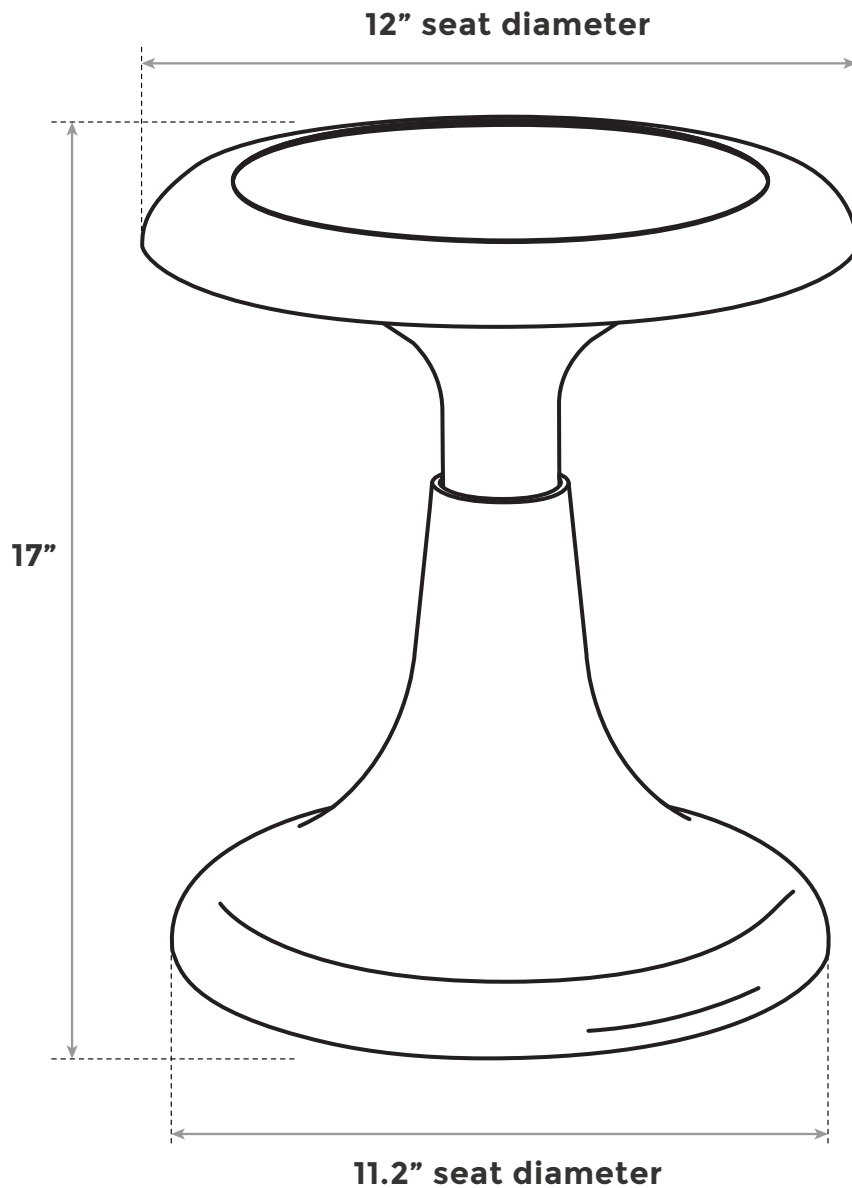

<b>Max weight load</b>	250 lbs.
<b>Stool material</b>	Plastic
<b>Seat material</b>	Rubber
<b>Dimensions</b>	15" H x 12" W
<b>Warranty</b>	1-year limited



For help with assembly, find our assembly instructions at <http://bit.ly/32ZfxpH>



For a more in-depth look at this product, see our product video at <http://bit.ly/332zmfH>

 For technical questions and support call 800-349-3839, email [info@upliftdesk.com](mailto:info@upliftdesk.com), or visit our chat service at [upliftdesk.com](http://upliftdesk.com)