

FRM291

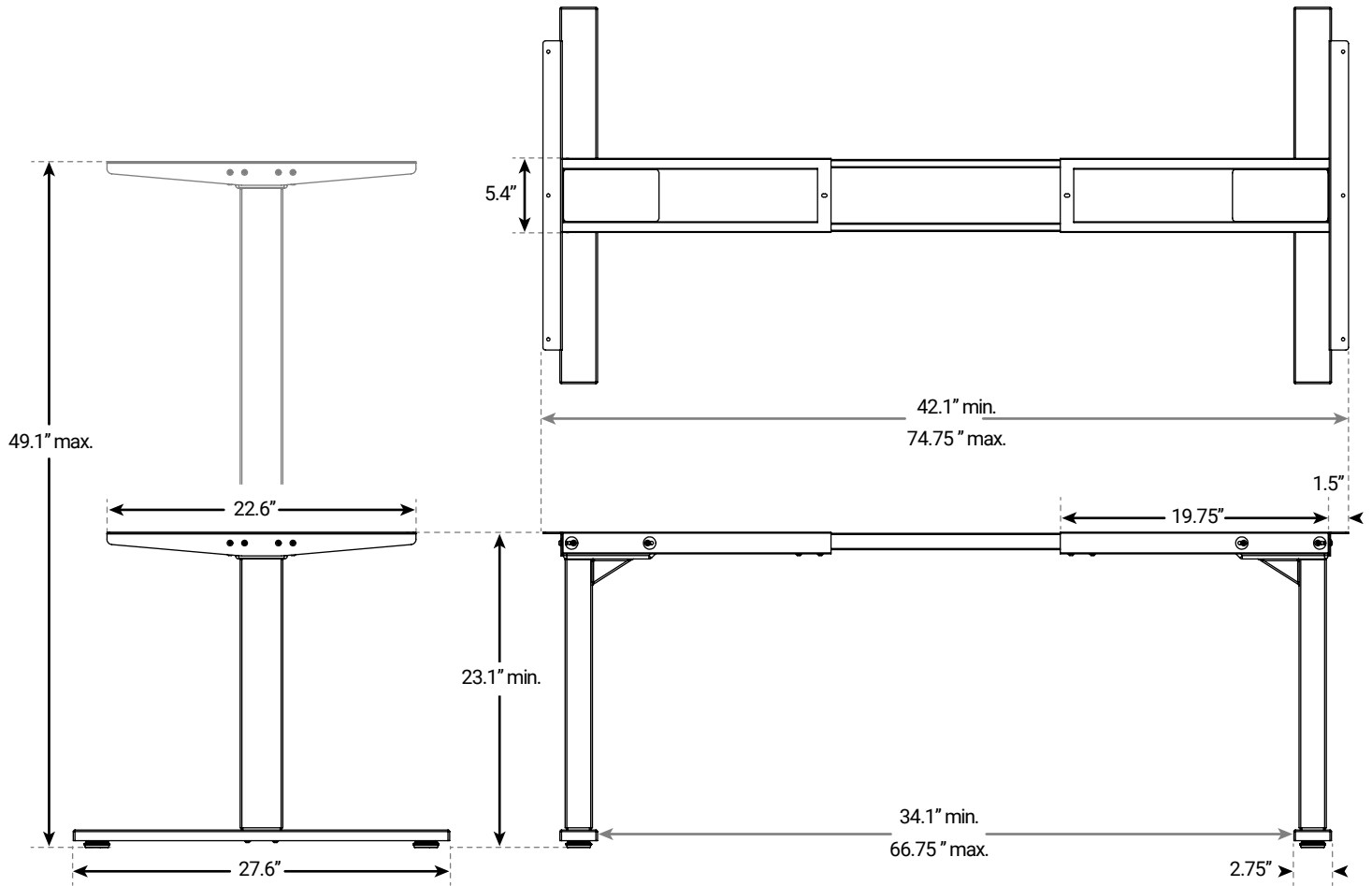

OPTIONAL PIECES

Casters (available in black or white)

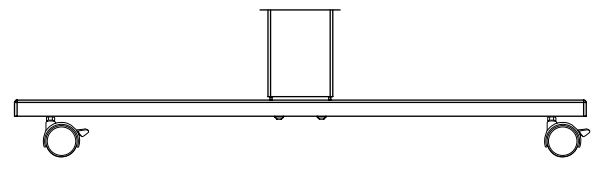

gives the desk mobility, and adds 1.25" to overall height

CAPABILITIES

Travel Speed	1.5"/second (varies depending on load)
Weight Capacity	355 lbs
Noise Level	45 decibels during motion
Adjustable Foot Levelers	3/8" adjustment for uneven flooring
Voltage	Input: 110V Output: 31V
Color	Black, Gray
Warranty	7-year All-Inclusive warranty (includes motor, frame, controller, keypad, electronics & mechanisms)

FEATURES

- 2-Stage lifting column with 26" of height adjustment, a quiet soft start and stop motor in each leg, and an energy saving transformer.
- Adjustable width telescoping base allows you to perfectly fit the base to your desktop and workspace
- Choose a standard 2-button keypad, or upgrade to the programmable Advanced Digital Memory Keypad.