

# UPLIFT DESK®

## 4-Leg Seated Height Side Table Frame

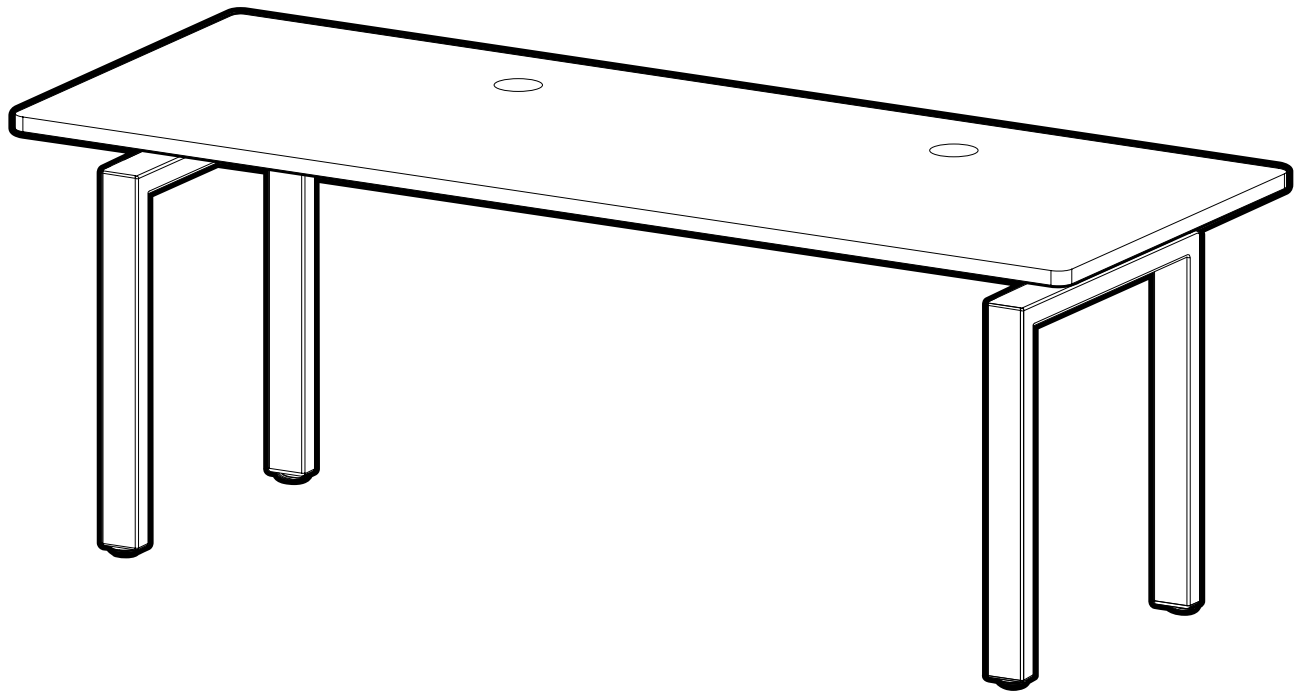

For assembly assistance,  
visit [upliftdesk.com/FRM411](http://upliftdesk.com/FRM411)  
call 800-349-3839 or email [support@upliftdesk.com](mailto:support@upliftdesk.com)

Patent Pending, ©2018 UPLIFT Desk®. All Rights Reserved



Thank you for choosing **UPLIFT Desk**.

## SAFETY AND WARNINGS



**WARNING:** Designed for use in dry work environments only. Use only indoors.

Please read this manual carefully. Inappropriate use of this table can cause property damage or bodily injury. Under no circumstances does the manufacturer accept warranty or liability claims for damages caused from improper use or handling of this table. Provide this manual to any new user.

## PACKAGE CONTENTS

Count all pieces before disposing of any carton or packing material. Use a padded or carpeted area for assembly to avoid damage. For ease and safety, we recommend two people for assembly.

You'll need:

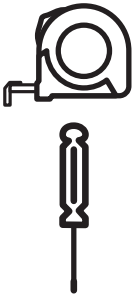

tape measure,  
and Phillips head  
screwdriver

## COMPONENTS

**C1** Leg assembly  
(qty 2)

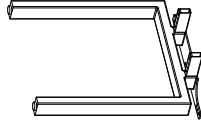

**C2** Crossbar end  
(qty 2)

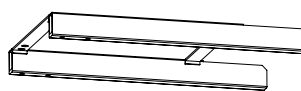

**C3** Crossbar rail  
(qty 2)



## HARDWARE

**H1** M8x8 Set screw  
(qty 16)



**H2a** #10-3/4"  
Screw  
(qty 8)



**H2b** #10-24x3/4"  
Screw  
(qty 8)



**H3** Washer  
(qty 8)



**H4** Allen wrench



## CONFIGURATION

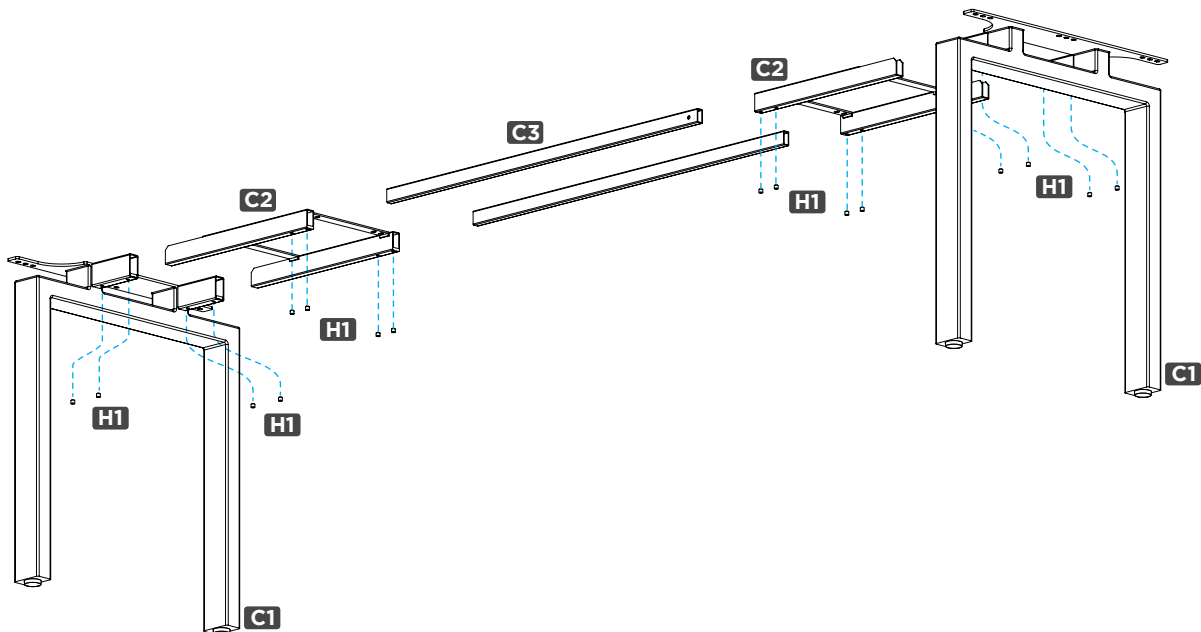

## ASSEMBLY INSTRUCTIONS

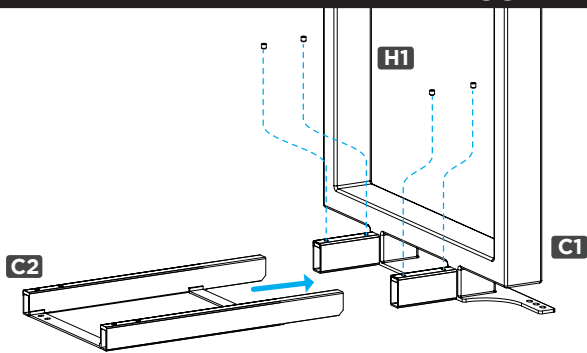

### Step 1

Slide a Crossbar end (C2) into the tube extensions on a Leg assembly (C1) in the orientation shown for each piece. Be sure to slide the Crossbar end in as far as it will go. Then lock the Crossbar end in place using four of the M8x8 Set screws (H1) using an Allen wrench. Repeat this step with the other Crossbar end and Leg assembly.

### Step 2

Orient the Crossbar rails (C3) so that the Center indicator marks are facing up.

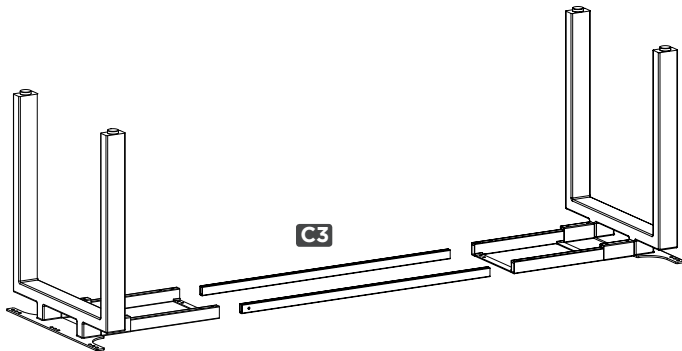
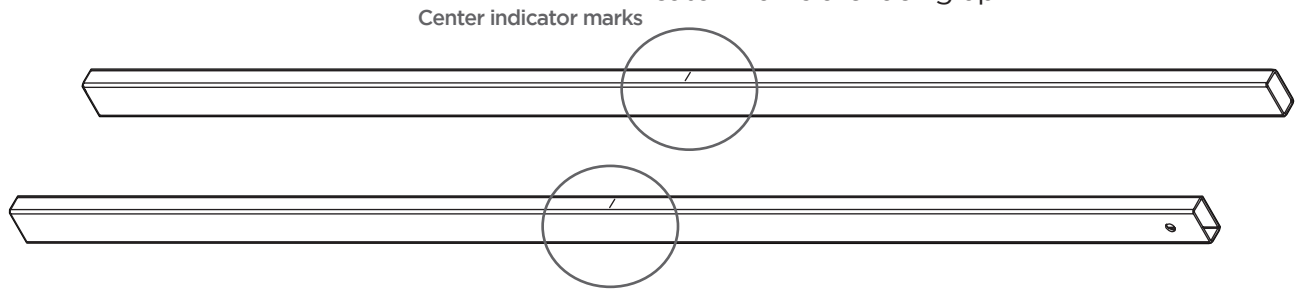

### Step 3

Slide the Crossbar rails (C3) into the Crossbar end of one of the assemblies from Step 1. Then, slide the second assembly from Step 1 onto the opposite ends of the Crossbar rails. Slide all parts together as far as they will go. Doing so will make the full assembly easier to lift onto the desktop in the next step.

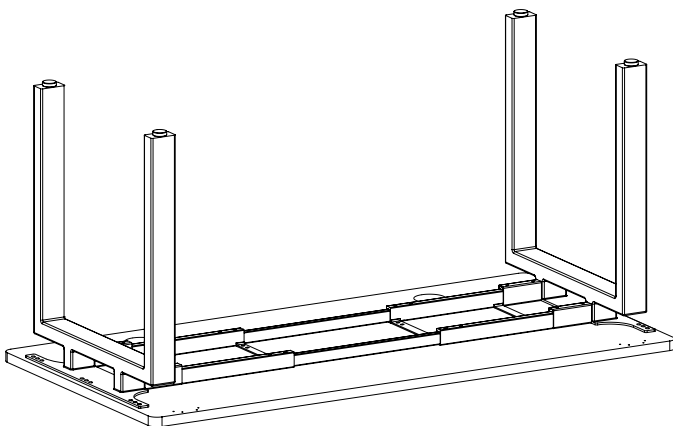

### Step 4

Before proceeding, inspect top surface of desktop for damage. We recommend placing a blanket on the floor to prevent the desktop from scratching. Place the UPLIFT desktop on the floor, with the mounting holes facing up. (If you are using your own desktop, there will not be mounting holes).

Next, place the completed frame assembly on top of the desktop, aligning the slots in the Leg assemblies with the metal inserts or pre-drilled holes in the desktop (Step 5 will help you determine which holes to use depending on your desktop's size). If needed, adjust the width of the frame in order to properly align all of the holes.

**Fig. A. 30" desktops**

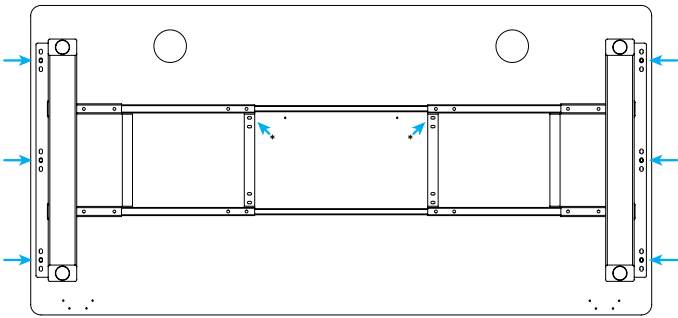

**Fig. B. 24" desktops**

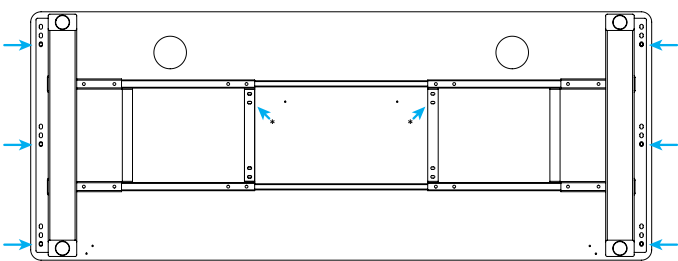

### Step 5

#### Determine which holes to use.

This frame is designed to attach to UPLIFT desktops from 42" to 80" wide and 24" or 30" deep. Refer to the arrows in Fig A. for proper screw placement on 30" deep desktops and Fig. B for 24" deep desktops.

For 30" deep desktops, first align the center slots of the Leg assemblies with the three mounting holes along each side of the desktop. The slot on the Crossbar End closest to the back of the desktop will line up with a mounting hole.

For 24"-deep desktops, align the three mounting holes along each side of the desktop with the outer slots in the Leg assemblies, which allows the assembly to be centered on the desktop. If the frame assembly hangs off the front or back of the desktop, use the outer slots on the opposite sides of the center slots. The slot on the Crossbar End second-closest to the back of the desktop will line up with a mounting hole.

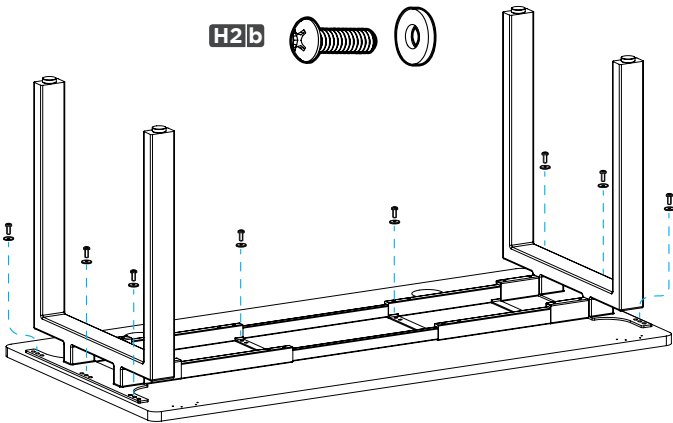
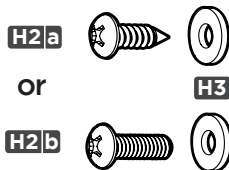

### Step 6

#### Determine which type of screw to use.

If your pre-drilled desktop does not have metal threaded inserts, use the #10x3/4" Screws (H2a).

If your pre-drilled desktop does have metal threaded inserts, use the #10-24x3/4" Screws (H2b).

After ensuring that the table frame is properly positioned, attach the frame to the desktop using eight of the chosen screws (H2a or H2b) and eight Washers (H3).

Make sure all screws are started before tightening completely. Be careful not to over-tighten to avoid stripping.

If you have purchased casters for your side table, install them now. Unscrew the leveling glides already in the legs, and screw in the casters in their place.

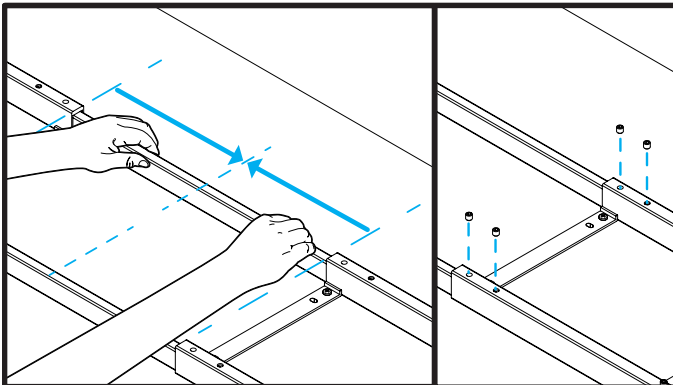

### Step 7

Slide in each Crossbar rail (C3) until the Center indicator mark is in the middle. Once this is done, the Crossbar rail will be centered and in the proper position.

Insert the eight remaining M8x8 Set screws (H1) into the Crossbar ends (four on each side) to secure each Crossbar rail, then tighten using the Allen wrench (H4).

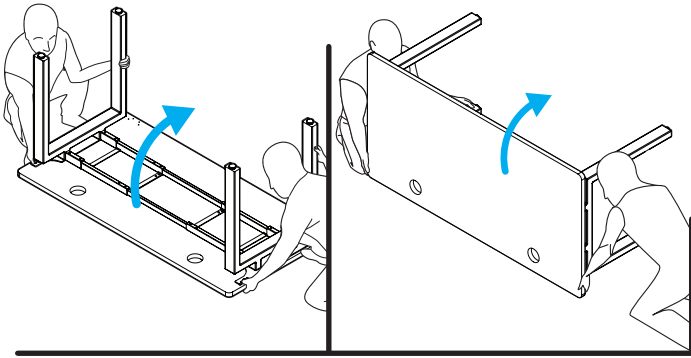

### Step 8

With you and your friend on opposite ends of the table assembly, grab the desktop with one hand and the Leg assembly with the other hand, as shown.

Support both the frame and the desktop equally, and gently rotate the table 90 degrees onto its side.

Readjust your grip and rotate another 90 degrees, so that your table is right-side up. Adjust the leveling studs or casters as needed to make the table level on your floor.

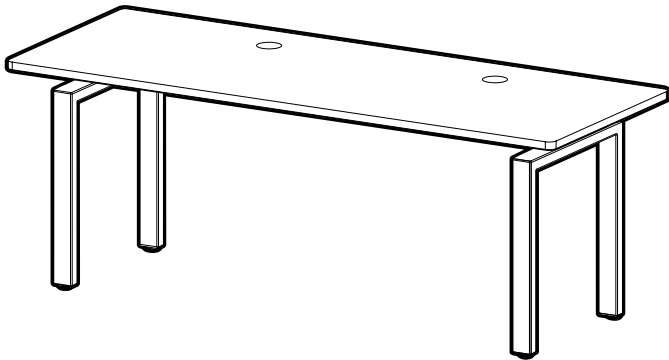

### Step 9

Position your table where you'd like it to be.

**If you installed casters:** Moving is easy! Make sure the casters are unlocked and roll it to the desired location.

**If you did not install casters:** Using two people, lift your desk (do not drag it) by holding onto the part of the Leg assembly that is secured to the desktop.

**Note:** Never lift by holding on to the Desktop itself, as this will put undue stress on the screws.



# UPLIFT DESK®

Work Better. Live Healthier

512-614-3152

800-349-3839

info@upliftdesk.com

upliftdesk.com

## SAVE THESE INSTRUCTIONS

Study this manual carefully. If this desk is sold, please provide this manual to the buyer, installers, or support personnel operating the product.



**Copyright Notice:** This guide is a component of the UPLIFT Desk™. This guide is a part of the scope of delivery, even if the item is resold. This guide is also available on the UPLIFT Desk website: upliftdesk.com. Excerpts or copies may not be forwarded to third parties or used in any other published form without the prior written consent of UPLIFT Desk. These instructions are subject to United States copyright law.