

UPLIFT V2 Commercial Standing Desk T-Frame

SKU: FRMA-2

Specifications

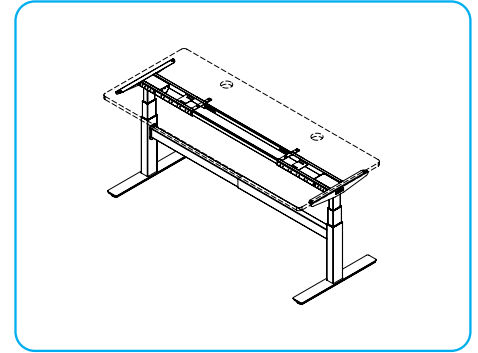
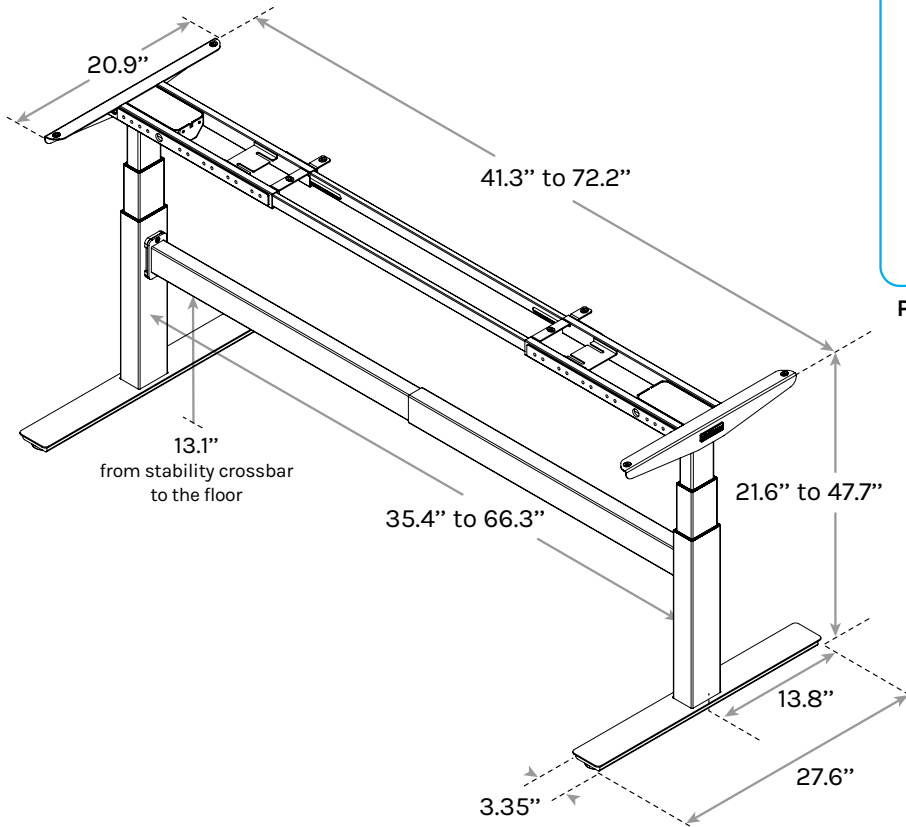

Pictured: frame and desktop placement



Contract-grade Quality



7-year Warranty

Height Range	21.6"-47.7"
Travel Speed	1.57"/second
Noise Level	50 dB
Lifting Capacity	355 lbs
Current	4 amps max (during movement)
Voltage	Input: 100-120Vac (50/60Hz) Output: 24Vdc



For help with assembly, see our assembly video at upliftdesk.com/2leg-com-t

BIFMA Meets BIFMA G1-2013 Height Standard



Dual Motor Design



3-Stage Legs are 33% Faster than 2-Stage Legs



Superior Anti-Collision Sensitivity



48 Accessory Mounting Points



Stability Crossbar



Improved Stability with 33% Larger, Precision Tolerance Legs



Whisper-Quiet Adjustment



Included Under-Desk Wire Management



Available in 4 Color Options

BIFMA Meets BIFMA X5.5-2014 Durability Standard

For technical questions and support call 800-349-3839, email info@upliftdesk.com, or visit our chat service at upliftdesk.com