

UPLIFT V2 Standing Desk

SKU: FRMA-2

Specifications

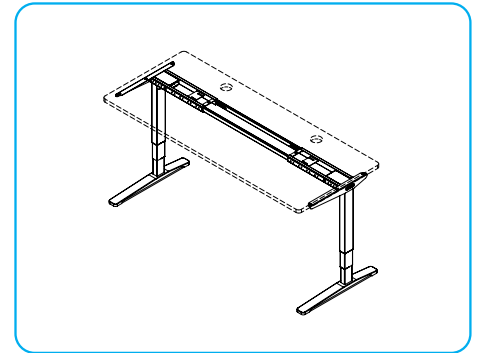

Pictured: frame and desktop placement

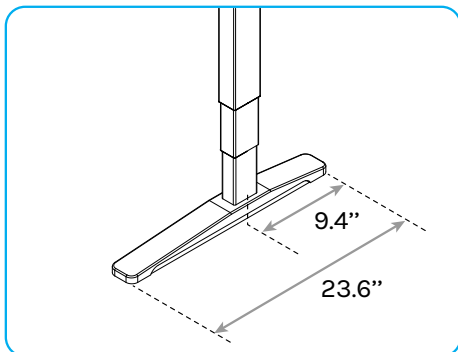
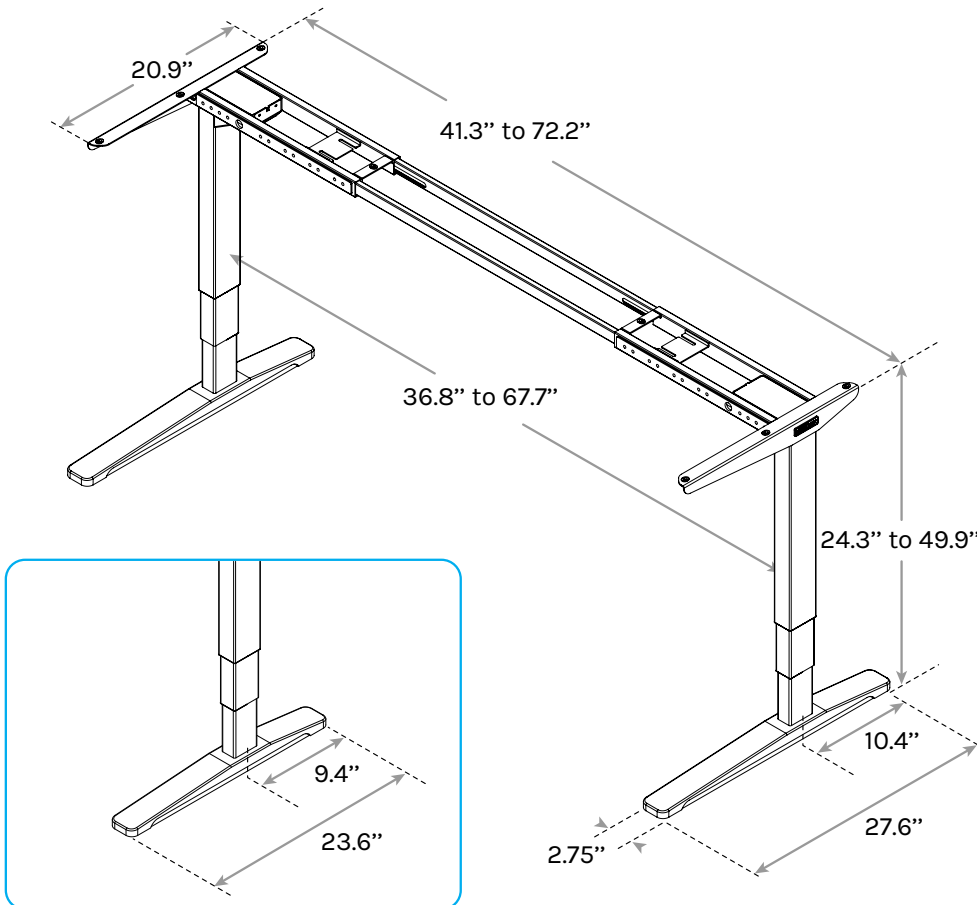

Also available with shorter feet for 24" deep and 120° desktops



Contract-grade Quality

Height Range	24.3"-49.9"
Travel Speed	1.57"/second
Noise Level	50 dB
Lifting Capacity	355 lbs
Current	4 amps max (during movement)
Voltage Input	100-120Vac, 50/60Hz, 400W max
Warranty	15 Year



Dual Motor Design



3-Stage Legs Are 33% Faster Than 2-Stage Legs



Superior Anti-Collision Sensitivity



48 Accessory Mounting Points



Stability Brace on Each Leg



Improved Stability with Precision Tolerance Legs



Whisper-Quiet Adjustment



Included Under-Desk Wire Management



Available in 4 Color Options



Meets BIFMA X5.5-2014 Durability Standard



For help with assembly, see our assembly video at upliftdesk.com/2leg-srd

For technical questions and support call 800-349-3839, email info@upliftdesk.com, or visit our chat service at upliftdesk.com