

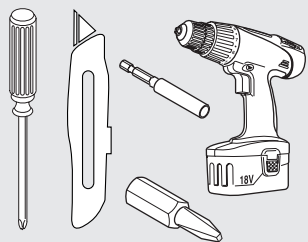

campfire™ big table with trough

Assembly Instructions

tools needed



assembly video



myturnstone.com/campfire/instructions

time needed



assemble time:
40 minutes

difficulty scale



really
easy

a little
more difficult

Here's what's in the box

BOX #1

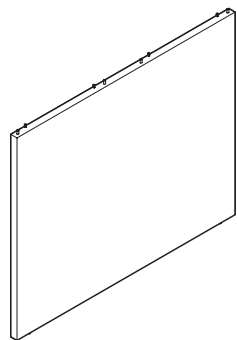

leg (2)

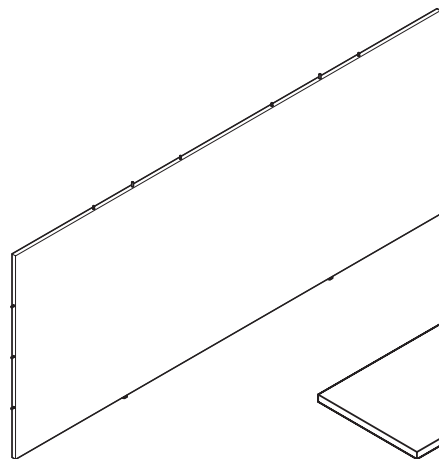

middle support (1)

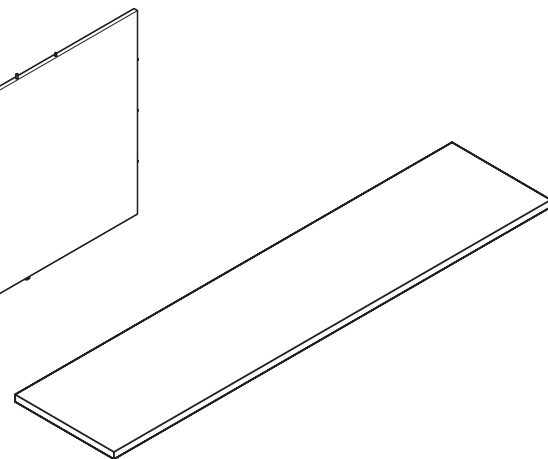

half worksurface (2)

BOX #4

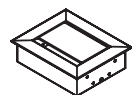

electrical (2)

BOX #5

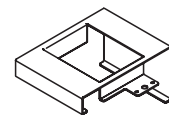

trim plate (2)

For assembly videos go to myturnstone.com/campfire/instructions

BOX #2

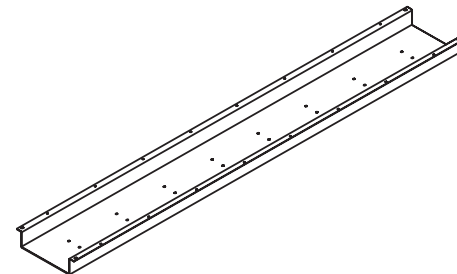

trough (1)

BOX #3

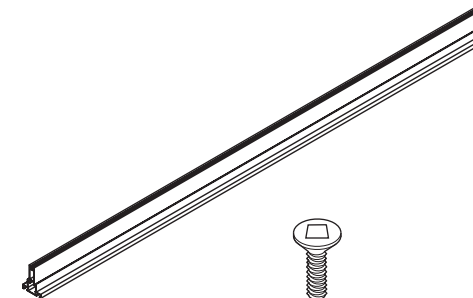

rail (1)



X screw (16)
size: #10 x 1.075"



T-slot fastener (16)

STEP

1

Add legs.

tips

The big table is appropriately named... that's because it is, in fact, big. Because of this, we recommend you install it where you want it to stay.

The glides on the bottom of the table can be raised to allow power cords to slide underneath. You will want to do this before the table is assembled.

- Find the two leg pieces and place upright.
- This might be an excellent time to call over a friend for help as you position the large center piece in-between the two end pieces. Secure one leg, then proceed to attach the second. The holes will line up with the metal pieces extruding from the middle piece.
- Once snapped into place, tighten the cam-locks.
- Do this on both sides, for a total of six times.
- Add cam covers.

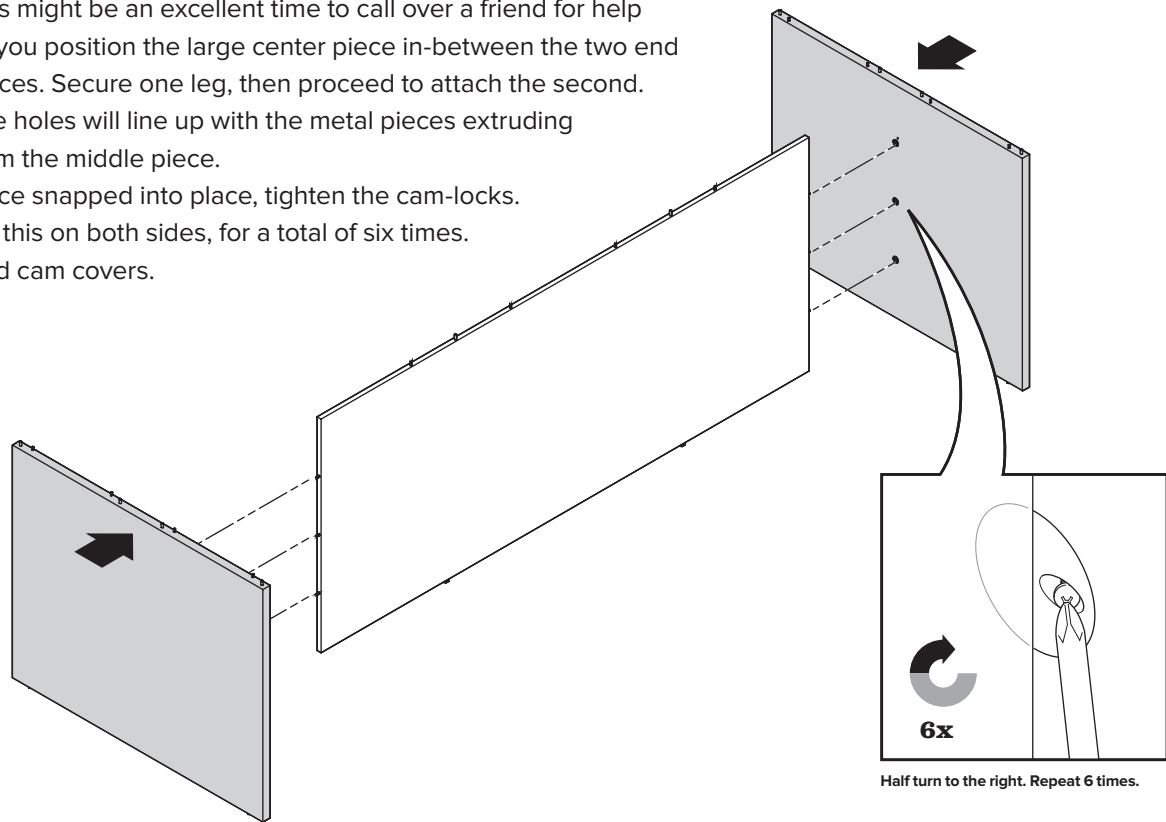

Half turn to the right. Repeat 6 times.

STEP

2

Add half worksurface.

tip

Make sure the cam-locks on the worksurface are turned to the left before you place the worksurface onto the leg structures.

- Ask a friend for help to lift the first half worksurface onto the leg structure. You'll notice the edge that faces outward is slightly rounded and the inside edge is straight.
- Carefully line up the holes on the bottom of the worksurface with the metal extrusions on the top of the base.
- After the worksurface top is in place, tighten the cam-locks underneath the table.

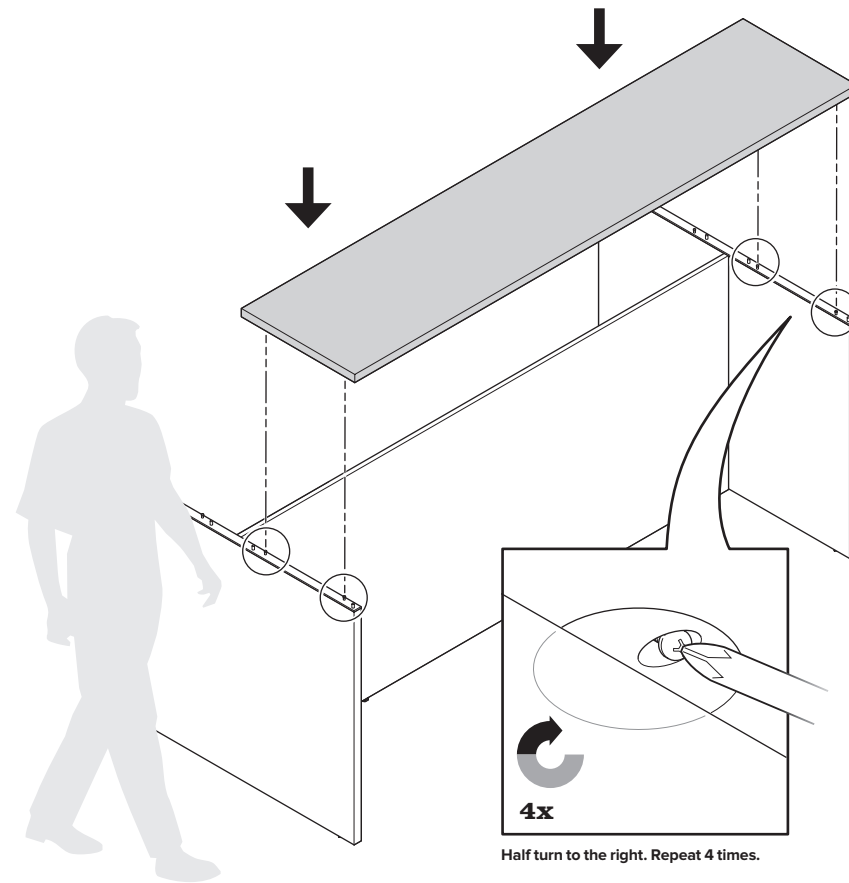

Half turn to the right. Repeat 4 times.

STEP 3

Install T-slot fasteners.

tip

Use the packaging to balance the trough on its side to easily connect the fasteners.

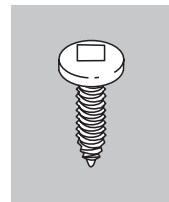

Use X screw.
size: #10 x 1.071"

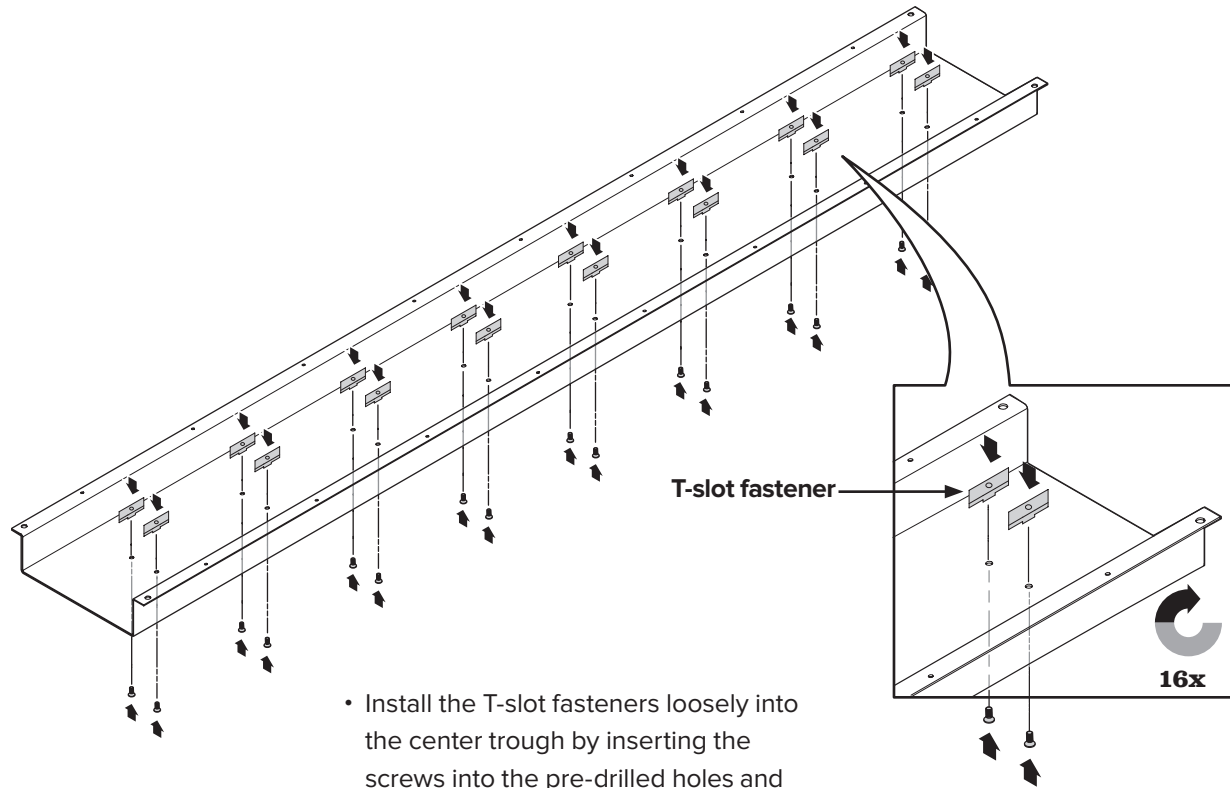

- Install the T-slot fasteners loosely into the center trough by inserting the screws into the pre-drilled holes and turning loosely from the bottom.

1 2 **3** 4 5 6 7 8 9 10 11

STEP 4

Install trough and tighten.

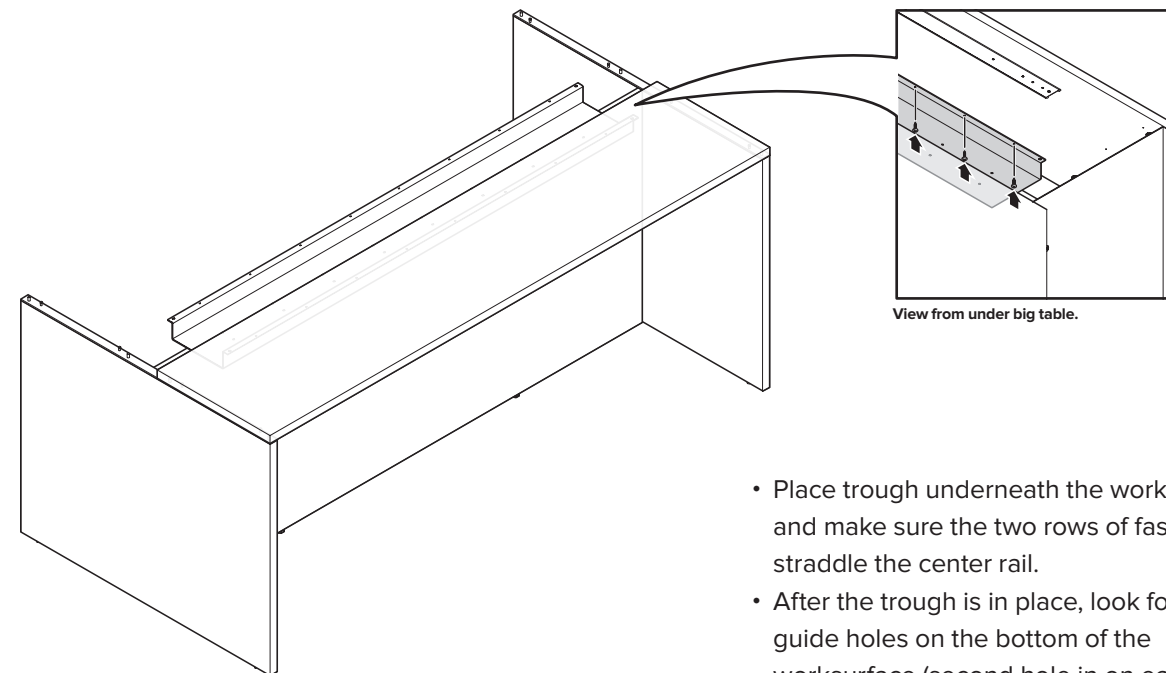

View from under big table.

- Place trough underneath the worksurface and make sure the two rows of fasteners straddle the center rail.
- After the trough is in place, look for the guide holes on the bottom of the worksurface (second hole in on each side) to help align the trough. Tighten from underneath using screw X.

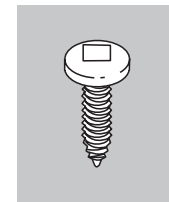

Use X screw.
size: #10 x 1.071"

1 2 3 **4** 5 6 7 8 9 10 11

STEP

5

Install trough-end trim plates.

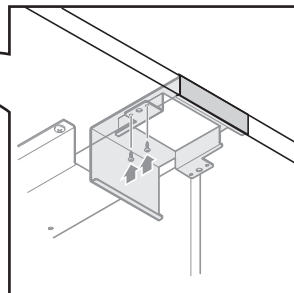
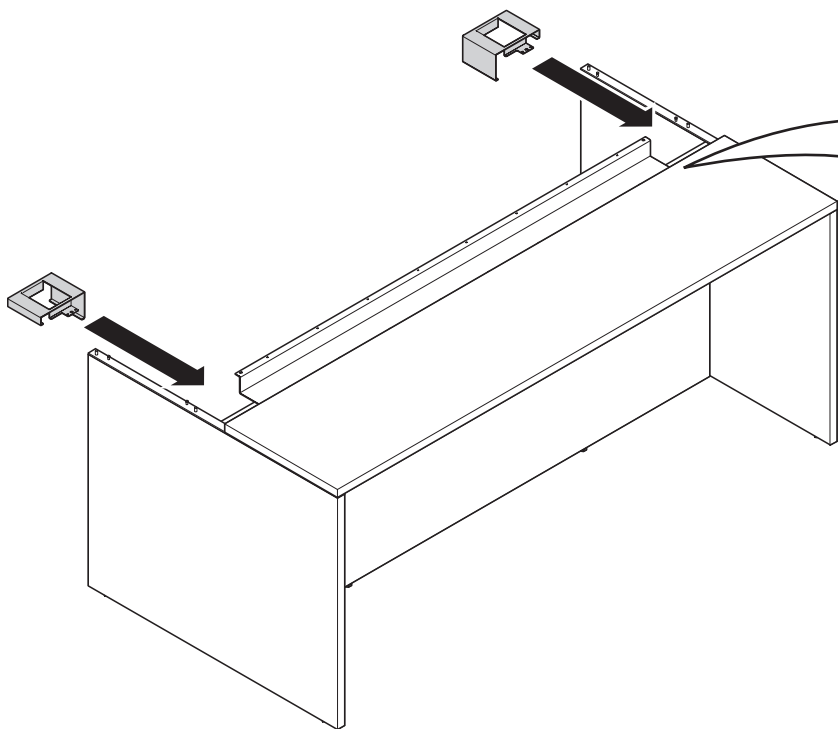

View from under big table.

- Install the trough-end trim plates. Be sure the longer side of the trim plate goes on the inside and the lip covers the edge of the leg.
- After the trim plates are in place, tighten from underneath the installed worksurface using the X screws.

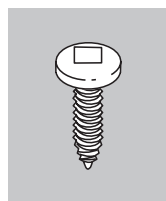

Use X screw.
size: #10 x 1.071"

1 2 3 4 **5** 6 7 8 9 10 11

STEP

6

Install other half worksurface.

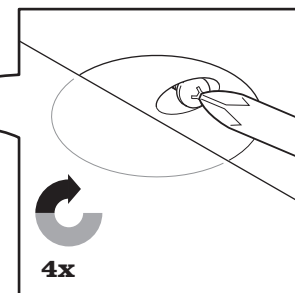
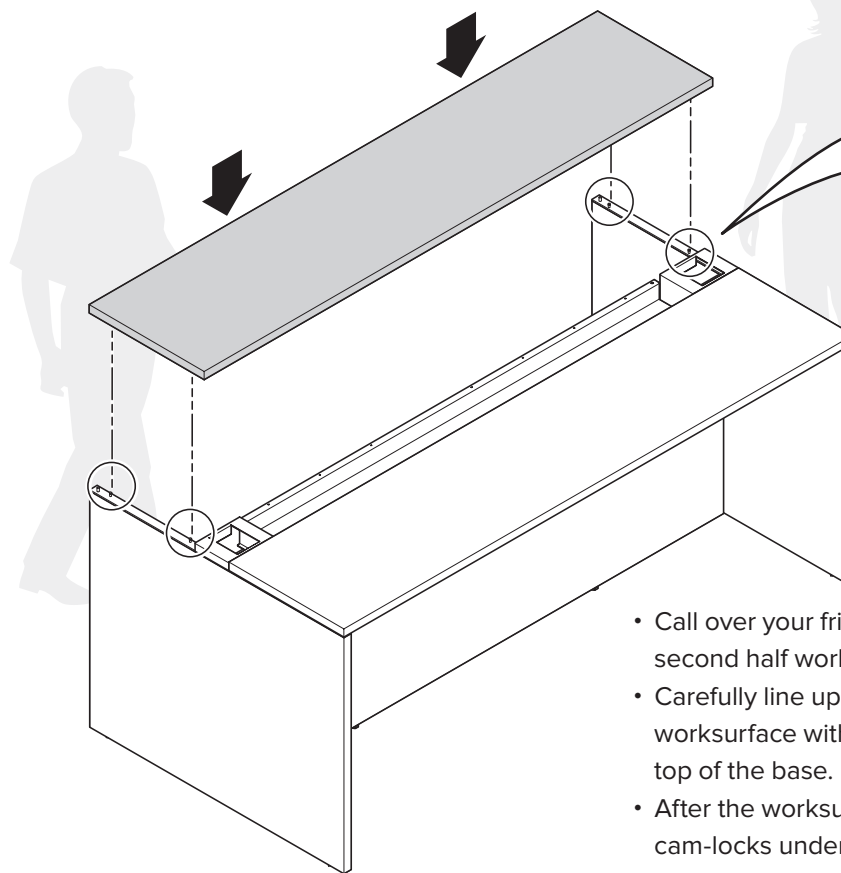

Half turn to the right. Repeat 4 times.

- Call over your friend again to help place the second half worksurface onto the leg structure.
- Carefully line up the holes on the bottom of the worksurface with the metal extrusions on the top of the base.
- After the worksurface top is in place, tighten the cam-locks underneath the table.

tip

Make sure the cam-locks on the worksurface are turned to the left (Just like in step 2).

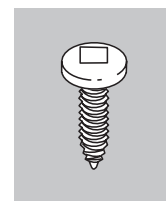

Use X screw.
size: #10 x 1.071"

1 2 3 4 5 **6** 7 8 9 10 11

STEP

7

Tighten trough to work surface.



Use X screw.
size: #10 x 1.071"

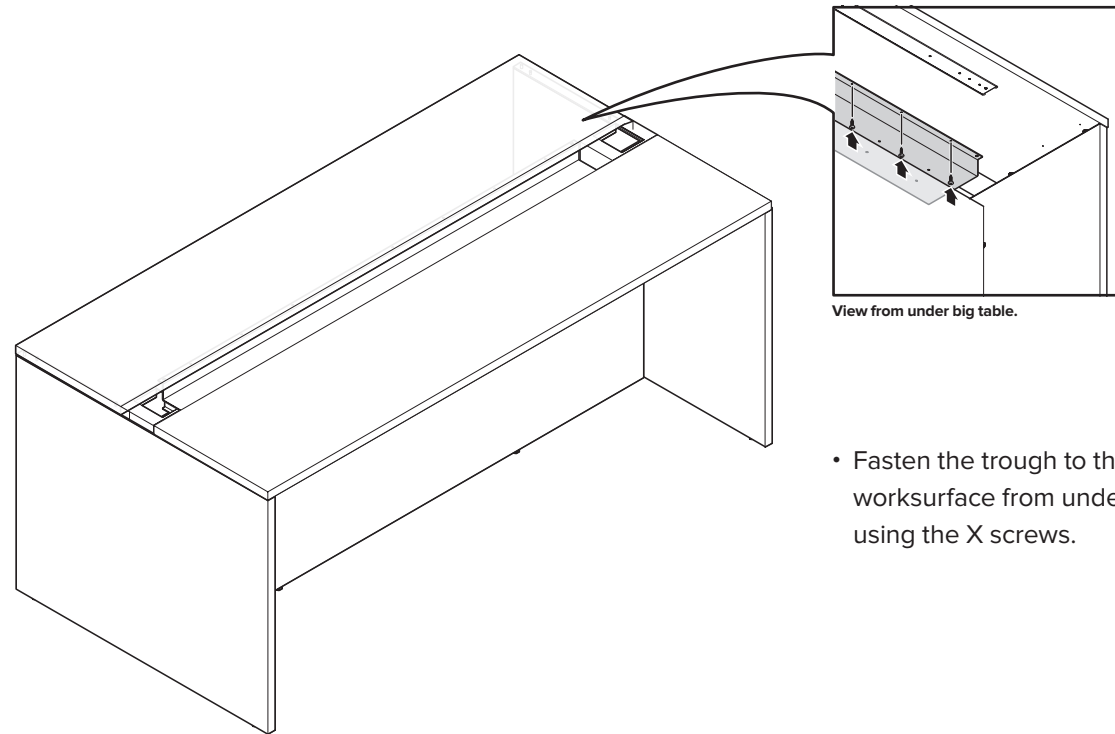

- Fasten the trough to the half work surface from underneath using the X screws.

1 2 3 4 5 6 **7** 8 9 10 11

STEP

8

Tighten trim plate.

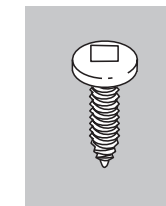

Use X screw.
size: #10 x 1.071"

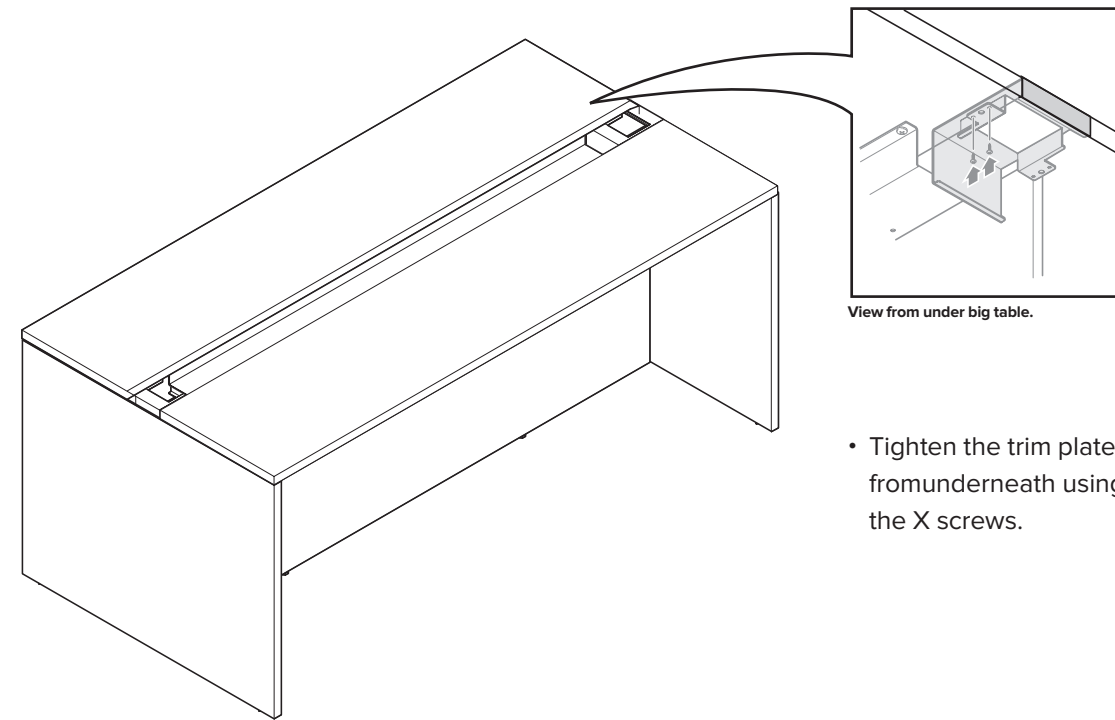

- Tighten the trim plates from underneath using the X screws.

1 2 3 4 5 6 7 **8** 9 10 11

STEP 9

Install electrical.

tip

The outlets pop open by pressing on the top. Once they are installed, the electrical outlet will face the center of the table.

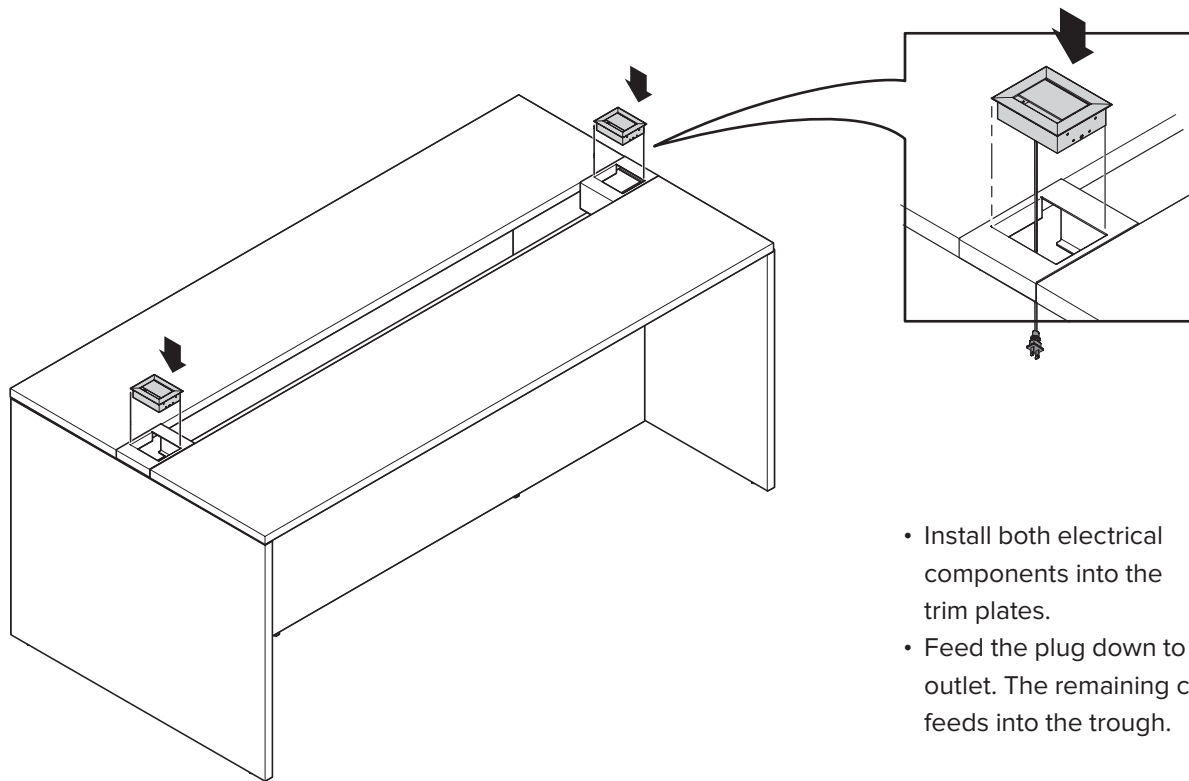

- Install both electrical components into the trim plates.
- Feed the plug down to the outlet. The remaining cord feeds into the trough.

STEP 10

Connect electrical lines.

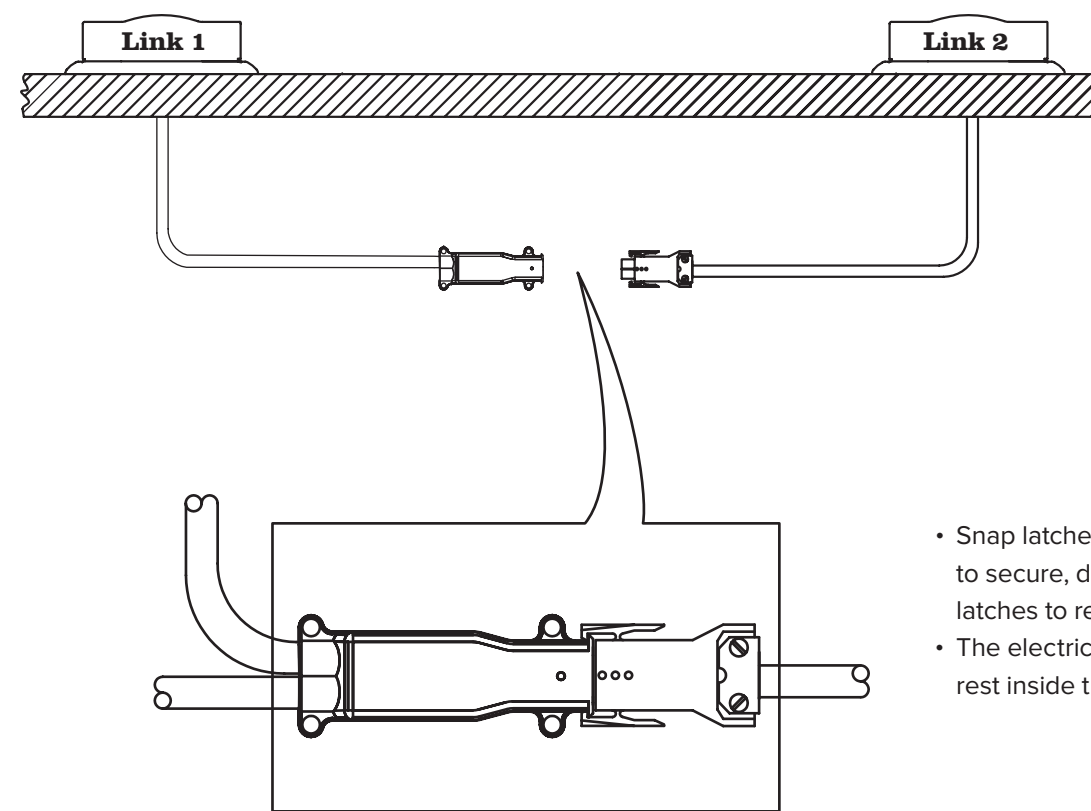

- Snap latches into place to secure, depress latches to release.
- The electrical lines will rest inside the trough.

STEP

11

Install
center rail.

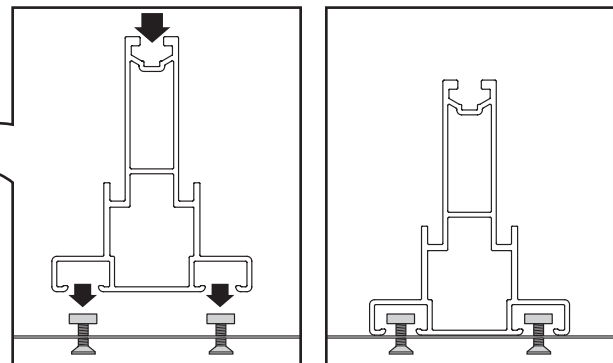
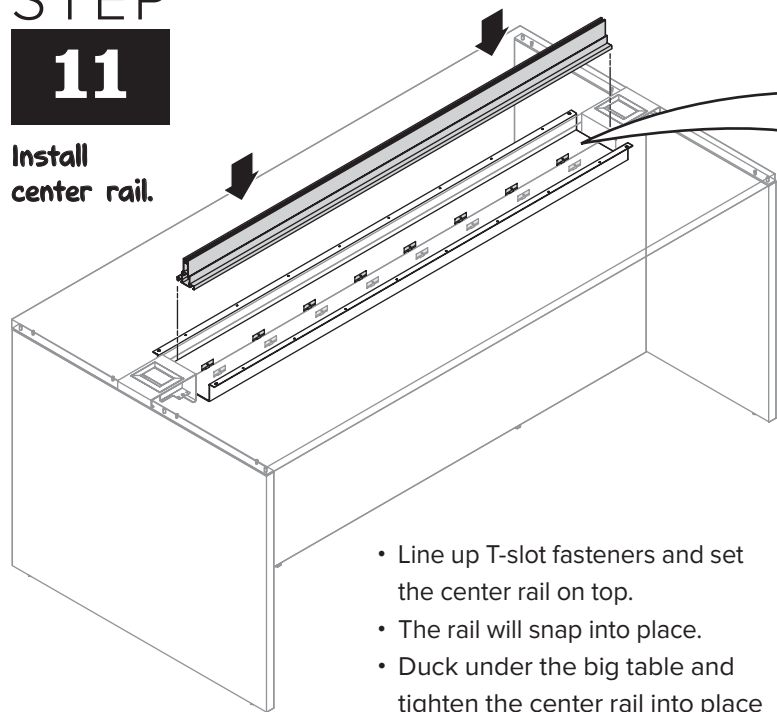

End view.

End view.

- Line up T-slot fasteners and set the center rail on top.
- The rail will snap into place.
- Duck under the big table and tighten the center rail into place by rotating the T-slot fasteners.

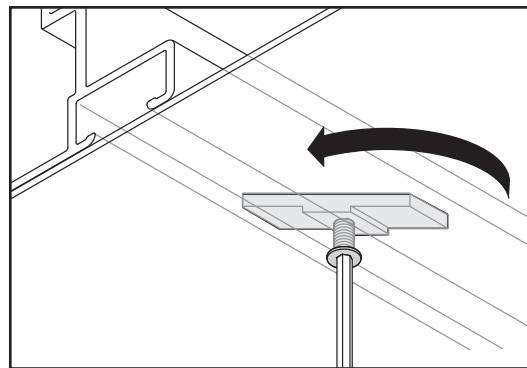

1

2

3

4

5

6

7

8

9

10

11

Visit myturnstone.com to see more spots.





turnstone®



800.531.3746 • info@thehumansolution.com • thehumansolution.com

All rights reserved. ©2010 Steelcase Inc. Printed in the U.S.A. on recycled paper. ⓘ Data subject to change. Trademarks used herein are the property of Steelcase Inc. Some products and services may not be available in all countries. Your Turnstone representative can provide you with details.
ad-stock ID 10-0003018. **Campfire Big Table with Trough Assembly Instructions: 11/10**
engineering document 939500545 rev A.