

# UPLIFT DESK<sup>®</sup> 3-Drawer File Cabinet, Rolling STR003

## Package Contents



Main Unit



Casters  
(qty 2)



Locking Casters  
(qty 2)



Screws  
(qty 16)

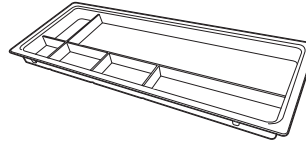

Tray  
(optional)

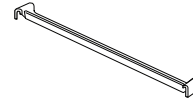

Hanging folder bar  
(optional)



Keys  
(qty 2)

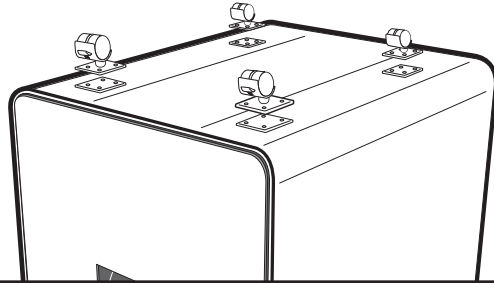

### Step 1

After un-boxing, grab a friend to help you place the Main unit upside down. Screw the Locking casters into the holes located at the front, and the regular Casters into the holes at the back. You and your friend can now flip the pedestal over safely. After resting it upright on the floor, test out the Casters by rolling the pedestal around a bit.

To keep your pedestal stationary, simply flip the tabs on the Locking casters into the "down" position.

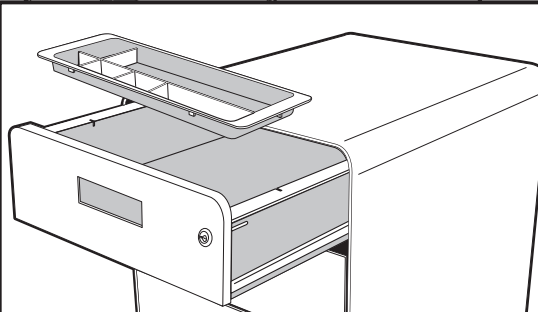

### Step 2

Open either of the top two drawers and insert the Tray into the drawer of your choosing. There will be small notches on either side of the drawer, to slide the Tray into. These will keep the Tray in-place in the drawer.

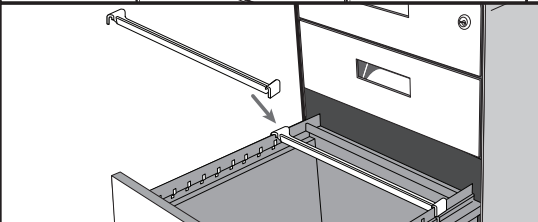

### Step 3

Legal size hanging folders will fit lengthwise (from front-to-back) and letter-size hanging folders will fit widthwise (from right-to-left). If you want your Letter size folders to hang front-to-back, insert the Hanging folder bar about 12.25" back in the bottom drawer, around where the last slot is located.

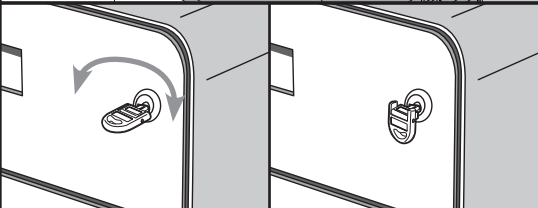

### Step 4

When you want to lock the drawers, simply insert the Key and rotate it 180° counterclockwise. To unlock the drawer, turn the Key back 180° clockwise.

To avoid losing your Key, you can leave it in the lock; just flip the tab down so it doesn't get snagged on your clothes or personal items.



Read all instructions before assembly. Failure to assemble properly may result in damage.



Do not stand on the unit. Do not stand in or lean on an open drawer.



To prevent the unit from tipping over, only have one drawer open at a time.

© Copyright Notice: This guide is a component of the UPLIFT Desk 3-Drawer File Cabinet, Rolling. This guide is a part of the scope of delivery, even if the item is resold. This guide is also available on the UPLIFT Desk website: [upliftdesk.com](http://upliftdesk.com). Excerpts or copies may not be forwarded to third parties or used in any other published form without the prior written consent of UPLIFT Desk. These instructions are subject to United States copyright law.