

Range Single Monitor Arm

SKU: MON020

UPLIFT DESK

Package Contents

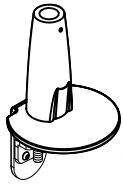

Base



Bottom plate



Extension arm

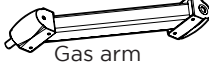

Gas arm



Monitor joint



VESA mount



13 mm Flat wrench



Monitor screw (qty 4)



Wire clips (qty 4)



Allen wrenches (set of five: 2 mm, 3 mm, 4 mm, 6 mm, and 6.5 mm)

Parts for Bolt-through assembly



Bolt-through top



Long bolts (two sizes included: 50 mm & 70 mm)

Note: There are two ways to attach to your desktop: **Clamp** and **Bolt-through** mount. Determine if you need to attach it around the back side of your desk (follow Step 1.1) or through a hole from 0.4" to 3.15" in diameter (follow Step 1.2).

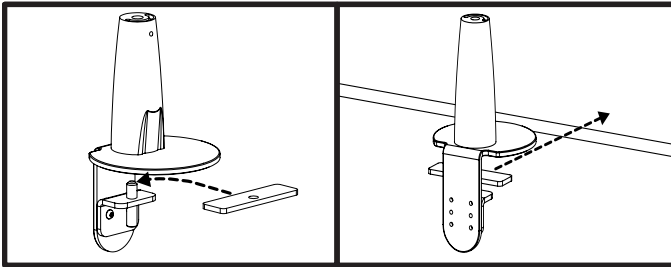

Step 1.1 - Clamp

Rest the Bottom plate on the Base's bolt. Next, fit the Base around the back edge of your desk, and using the 6.5 mm Allen wrench, tighten the Long bolt & Bottom plate into place.

When placing the Bottom plate on the Base's bolt, make sure the edge farthest from the hole is facing the back of the Base and the edge closest to the hole aligns with the front edge of the Bottom clamp. If you're attaching this to a UPLIFT V2 4-Leg Desk, this is the only way it will fit properly.

fig. 1

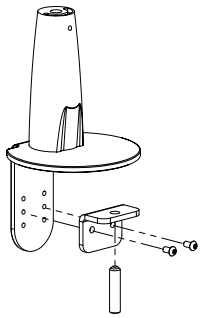
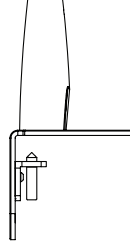
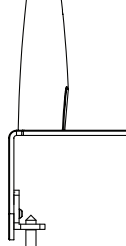

fig. 2



min thickness 0.75"

fig. 3



max thickness 3.75"

Note: If the Clamp does not fit on your desk edge, you can increase or decrease the space between the Clamp by removing the bottom of the Clamp and the Bolt, and repositioning them. Using the 4 mm Allen wrench, unscrew the two screws holding the bottom of the Clamp (see fig. 1).

For thinner desks (0.75" minimum), reassemble the Clamp as shown in fig. 2. For thicker desks (3.75" maximum), reassemble the Clamp, as shown in fig. 3.

Note: If you're mounting this to an UPLIFT V2 4-Leg Desk, 2.5" will be the maximum thickness that will work with the Clamp.

Once the Clamp is sized and attached to your desktop as described above, continue on to Step 2.

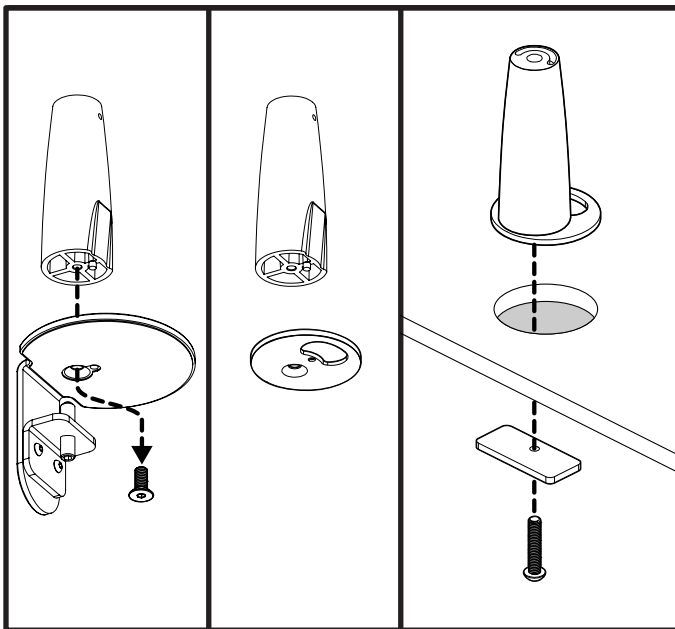

Step 1.2 - Bolt-through

To mount your monitor arm through a hole in your desktop, first measure the hole. It must be between a minimum of 0.4" and a maximum of 3.15" in diameter.

Prepare the Base for the Bolt-through mount by first loosening the screw under the Clamp with the 6 mm Allen wrench. **Note: screw may be tight.** Once removed, separate the Clamp assembly from the Base.

Place the Base onto the Bolt-through top, as shown. The Base's small peg should fit into the small hole on the Bolt-through top. Rotate until the large hole lines up with the notch at the front of the Base.

Place assembly completely over the hole, and facing the front of desk. Then, select a Long bolt: the 50 mm Bolt fits desks 0.6" to 1.38" thick, and the 70 mm Bolt fits desks 1.38" to 2.13" thick. Insert the Long bolt through the Bottom plate.

Note: The Bottom plate must straddle the hole's diameter. As long as the hole isn't larger than 3.15" than the Bottom plate will work. Thread the bolt into the Base assembly by hand and tighten using the 6 mm Allen wrench.

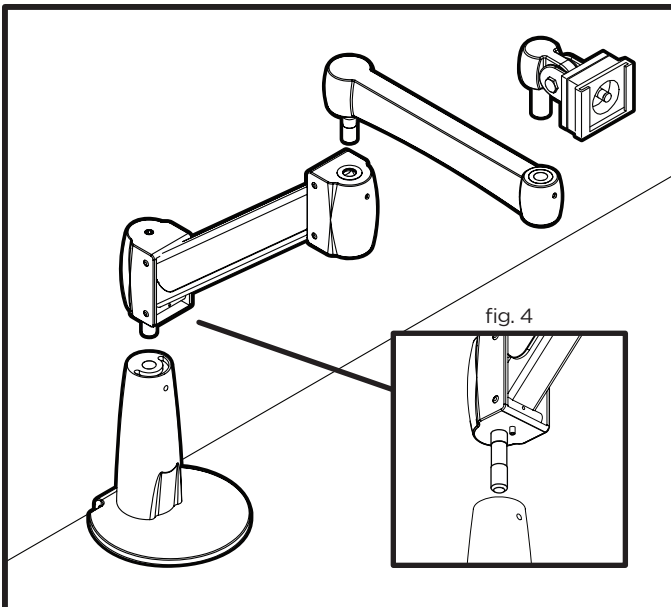

Step 2

With the Base attached to the desk, it's time to assemble the remainder of the arm by inserting the Gas arm, which ships with a pre-installed stopping pin at the bottom near the post (see fig. 4). This pin limits the arm's rotation to 180 degrees. If you want a full 360 degrees of rotation, remove this pin with the 2 mm Allen wrench. Then insert the Gas arm into the Base.

Insert the Extension arm into the Gas arm, and complete this part of the assembly by inserting the Monitor joint into the Extension Arm.

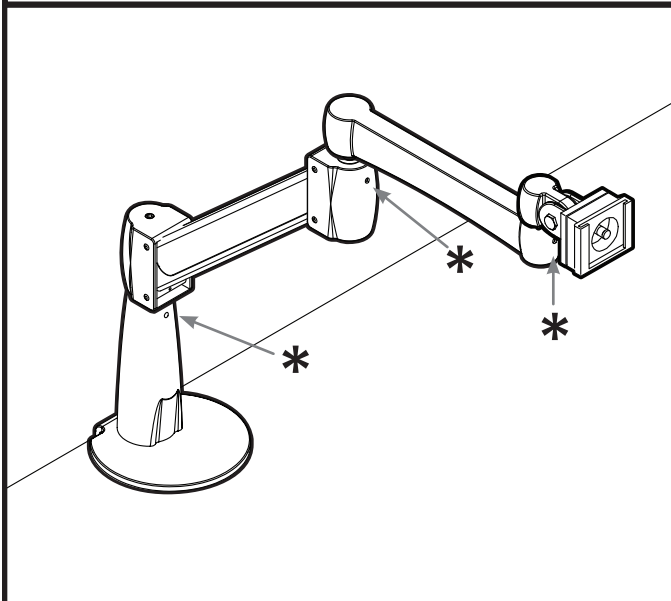

Step 3

After all components from Step 2 are in place, you may choose to tighten the set screws, which will lock all the components together, and prevent them from separating or drifting on their own.

They are located at each insertion point, and marked in this instruction book with a "*".

- At the top of the Base's neck, where the Gas arm is inserted.
- At the top of the Gas arm, where the Extension arm is inserted.
- And at the end of the Extension arm, where the Monitor joint is inserted.

Use the 3 mm Allen wrench provided. Make sure not to overtighten the set screws.

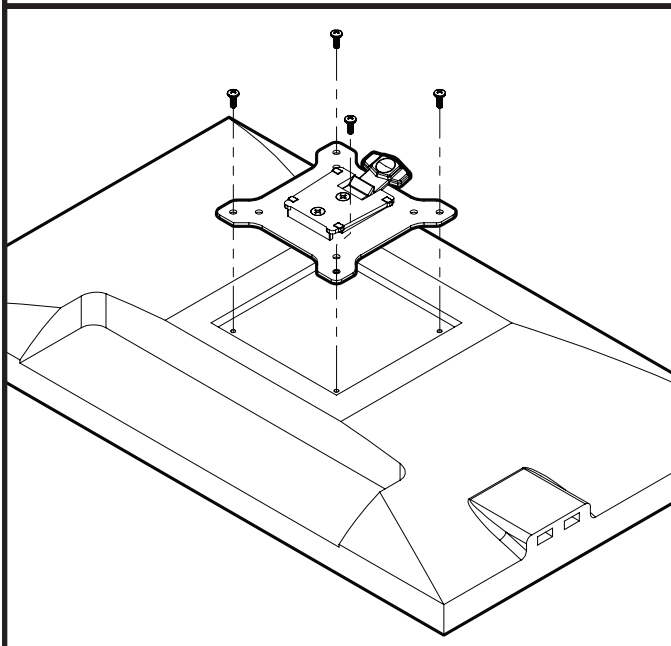

Step 4

Place your monitor face down on a flat surface, making sure not to scratch the screen. Next, attach the VESA mount to the back of your monitor using a Phillips-head screwdriver and four Monitor screws. The mount is designed to fit the industry standard VESA 75 mm & 100 mm hole patterns. Make sure the VESA mount is securely fastened to your monitor before moving on to the next step.

Note: make sure the tab on the VESA mount is facing the top of your monitor.

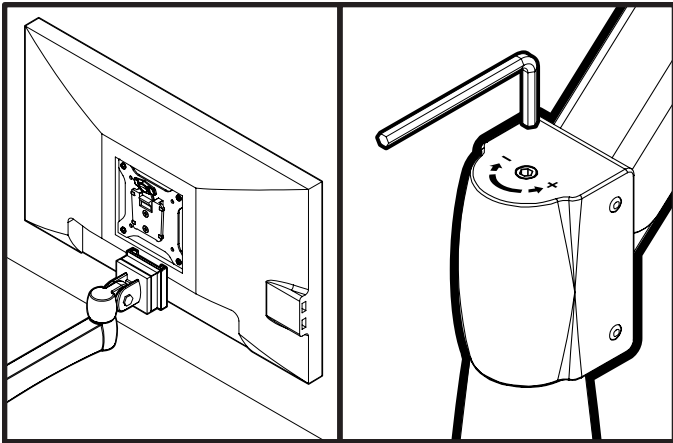

Step 5

Now, insert your monitor and VESA mount assembly into the Monitor joint mount, holding it firmly as you insert it until you feel it click into place.

The Range Gas arm tension is factory set for the heaviest monitor weight. To adjust the tension if the monitor is too light for the maximum setting, hold the Gas arm horizontal and, using 6 mm Allen wrench, turn the set screw located at the lower section of the arm toward the “-”.

Keep adjusting the tension until the monitor arm holds its position when you let it go.

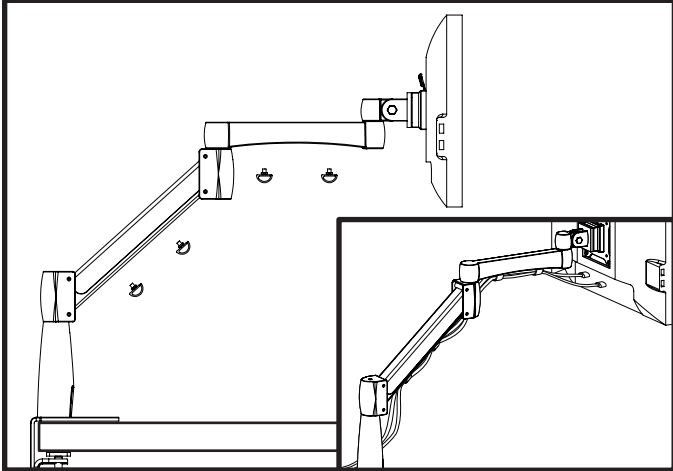

Step 6

Insert the Wire clips into the underside of the Extension arm and the Gas arm, and run your cables through them, making sure the cables are not pulled too tight. There should be some slack in the cables to allow the arm to move freely without being restricted.

Monitor Ergonomics

Screen Distance: Set your screen about an arm's length (approximately 18" - 28") from your eyes. If print is too hard to read, it is better to make the print larger on your screen than it is to move the screen closer to your eyes.

Monitor Height: The top of the monitor should be at or just below eye level.

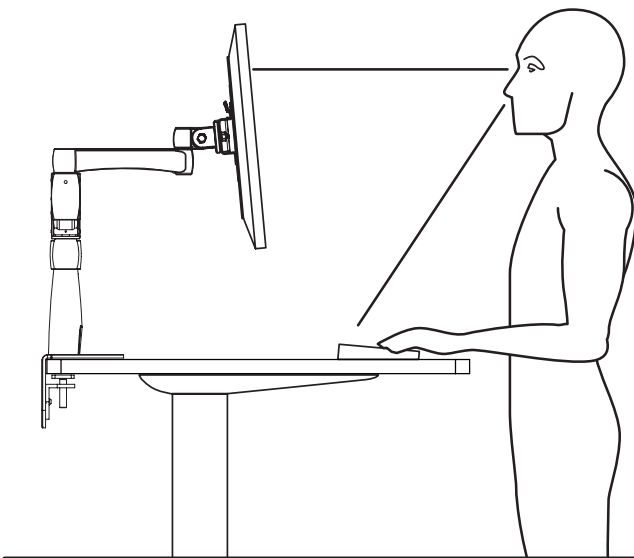

Monitor Tilt: The monitor should be tilted slightly up so it's easier to see the screen when the top of the monitor is level with your eyes. If the joint holding the monitor does not move, loosen the hex bolt on the Monitor joint **slightly** with the 13 mm Flat wrench.

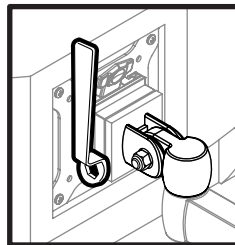

⚠ CAUTIONS & WARNINGS

⚠ **CAUTION:** Read all instructions before assembly. Failure to assemble or operate properly may result in damage or personal injury. Retain manual for future reference.

UPLIFT DESK[®]

Work Better. Live Healthier

512-614-3152

800-349-3839

info@upliftdesk.com

upliftdesk.com

SAVE THESE INSTRUCTIONS

Study this manual carefully. If this product is sold, please provide this manual to the buyer, installers, or support personnel operating the product.



Copyright Notice: This guide is a component of this UPLIFT Desk product. This guide is a part of the scope of delivery, even if the item is resold. This guide is also available on the UPLIFT Desk website: upliftdesk.com. Excerpts or copies may not be forwarded to third parties or used in any other published form without the prior written consent of UPLIFT Desk. These instructions are subject to United States copyright law.